

SD040 SD050

Liquid Cooled Diesel Engine Generator Sets

Standby Power Rating

40 KW 60 Hz / 40 KVA 50 Hz

50 KW 60 Hz / 50 KVA 50 Hz

Prime Power Rating

32 KW 60 Hz / 32 KVA 50 Hz

40 KW 60 Hz / 40 KVA 50 Hz

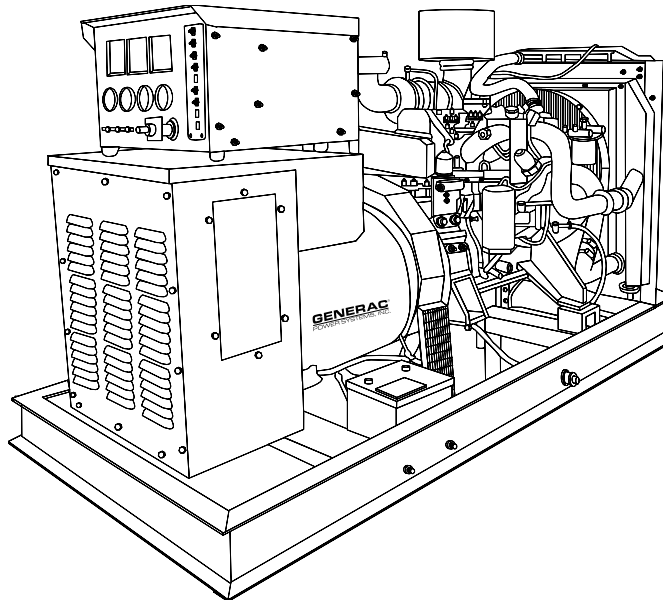

Power Matched

GENERAC 3.3DTA ENGINE

Turbocharged, Aftercooled

FEATURES

- **INNOVATIVE DESIGN & PROTOTYPE TESTING** are key components of GENERAC'S success in "IMPROVING POWER BY DESIGN." But it doesn't stop there. Total commitment to component testing, reliability testing, environmental testing, destruction and life testing, plus testing to applicable CSA, NEMA, EGSA, and other standards, allows you to choose GENERAC POWER SYSTEMS with the confidence that these systems will provide superior performance.
- **TEST CRITERIA:**
 - ✓ PROTOTYPE TESTED
 - ✓ SYSTEM TORSIONAL TESTED
 - ✓ ELECTRO-MAGNETIC INTERFERENCE
 - ✓ NEMA MG1 EVALUATION
 - ✓ MOTOR STARTING ABILITY
 - ✓ SHORT CIRCUIT TESTING
 - ✓ UL 2200 COMPLIANCE AVAILABLE
- **SOLID-STATE, FREQUENCY COMPENSATED VOLTAGE REGULATION.** This state-of-the-art power maximizing regulation system is standard on all Generac models. It provides optimized
- FAST RESPONSE to changing load conditions and MAXIMUM MOTOR STARTING CAPABILITY by electronically torque-matching the surge loads to the engine.
- **SINGLE SOURCE SERVICE RESPONSE** from Generac's dealer network provides parts and service know-how for the entire unit, from the engine to the smallest electronic component. You are never on your own when you own a GENERAC POWER SYSTEM.
- **ECONOMICAL DIESEL POWER.** Low cost operation due to modern diesel engine technology. Better fuel utilization plus lower cost per gallon provide real savings.
- **LONGER ENGINE LIFE.** Generac heavy-duty diesels provide long and reliable operating life.
- **GENERAC TRANSFER SWITCHES, SWITCHGEAR AND ACCESSORIES.** Long life and reliability is synonymous with GENERAC POWER SYSTEMS. One reason for this confidence is that the GENERAC product line includes its own transfer systems, accessories, switchgear and controls for total system compatibility.

GENERAC®

POWER SYSTEMS, INC.

APPLICATION & ENGINEERING DATA

SD040/050

GENERATOR SPECIFICATIONS

TYPE	Four-pole, revolving field
ROTOR INSULATION	Class H
STATOR INSULATION	Class H
TOTAL HARMONIC DISTORTION	<3%
TELEPHONE INTERFERENCE FACTOR (TIF)	<50
ALTERNATOR	Self-ventilated and drip-proof
BEARINGS (PRE-LUBED & SEALED)	1
COUPLING	Direct, Flexible Disc
LOAD CAPACITY (STANDBY)	100%
LOAD CAPACITY (PRIME)	110%

NOTE: Emergency loading in compliance with NFPA 99, NFPA 110, paragraph 5-13.2.6. Generator rating and performance in accordance with ISO8528-5, BS5514, SAE J1349, ISO3046 and DIN6271 standards.

EXCITATION SYSTEM

- BRUSHLESS
 - Magnetically coupled DC current ✓
 - Eight-pole exciter w/ battery-driven field boost ✓
 - Mounted outboard of main bearing ✓ - PERMANENT MAGNET EXCITER
 - Eighteen pole exciter ✓
 - Magnetically coupled DC current ✓
 - Mounted outboard of main bearing ✓
- REGULATION
- Solid-state ✓
 - ±1% regulation ✓

GENERATOR FEATURES

- Four pole, revolving field generator, directly connected to the engine shaft through a heavy-duty, flexible disc for permanent alignment.
- Generator meets the temperature rise standards for class "F" insulation as defined by NEMA MG1-32.6, while the insulation system meets the requirements for the higher class "H" rating.
- All prototype models have passed a three-phase symmetrical short circuit test to assure system protection and reliability.
- All prototype models are tested for motor starting ability by measuring the instantaneous voltage dip with a waveform data acquisition system.
- All models utilize an advanced wire harness design for reliable interconnection within the circuitry.
- Magnetic circuit, including amortisseur windings, tooth and skewed stator design, provides a minimal level of waveform distortion and an electromagnetic interference level which meets accepted requirements for standard AM radio, TV, and marine radio telephone applications.
- Voltage waveform deviation, total harmonic content of the AC waveform, and T.I.F. (Telephone Influence Factor) have been evaluated to acceptable standards in accordance with NEMA MG1-32.
- Alternator is self-ventilated and drip-proof constructed.
- Fully life-tested protective systems, including "field circuit and thermal overload protection" and optional main-line circuit breakers capable of handling full output capacity.
- System Torsional acceptability confirmed during Prototype Testing.

ENGINE SPECIFICATIONS

MAKE	DAEWOO
MODEL	3.3DTA
CYLINDERS	4
DISPLACEMENT	3.3 Liter (201 cu. in.)
BORE	102 mm (4.02 in.)
STROKE	100 mm (3.94 in.)
COMPRESSION RATIO	17.2:1
INTAKE AIR	Turbocharged/Aftercooled
NUMBER OF MAIN BEARINGS	5
CONNECTING RODS	4-Drop forged steel
CYLINDER HEAD	Cast iron with over head valve
PISTONS	4-Aluminum alloy
CRANKSHAFT	Forged steel

VALVE TRAIN

LIFTER TYPE	Solid
INTAKE VALVE MATERIAL	Silicon chrome
EXHAUST VALVE MATERIAL	Stellite
HARDENED VALVE SEATS	Standard

ENGINE GOVERNOR

- MECHANICAL (Gear Driven)

 - Standard
 - FREQUENCY REGULATION, NO-LOAD TO FULL LOAD ... 5.0%
 - STEADY STATE REGULATION
 - ±0.5%

- ELECTRONIC

 - Optional
 - FREQUENCY REGULATION, NO-LOAD TO FULL LOAD ... 0.5%
 - STEADY STATE REGULATION
 - ±0.25%

LUBRICATION SYSTEM

TYPE OF OIL PUMP	Gear
OIL FILTER	Full flow, cartridge
CRANKCASE CAPACITY	6.5 Liters (6.9 qts.)

COOLING SYSTEM

TYPE OF SYSTEM	Pressurized, closed recovery
WATER PUMP	Pre-lubed, self-sealing
TYPE OF FAN	Pusher
NUMBER OF FAN BLADES	6
DIAMETER OF FAN	520 mm (20.5 in.)
COOLANT HEATER	120V, 1800 W

FUEL SYSTEM

FUEL	#2D Fuel (Min Cetane #40)
	(Fuel should conform to ASTM Spec.)
FUEL FILTER	10 Micron full flow
FUEL INJECTION PUMP	Zexel "AS"
FUEL PUMP	Engine driven
INJECTORS	Pintel type, 2100 psi.
ENGINE TYPE	Direct injection
FUEL LINE (Supply)	6.35 mm (0.25 in.)
FUEL RETURN LINE	6.35 mm (0.25 in.)

ELECTRICAL SYSTEM

BATTERY CHARGE ALTERNATOR	45 Amps at 24 V
STARTER MOTOR	24 V
RECOMMENDED BATTERY	(2)—12 V, 90 A.H., 27F
GROUND POLARITY	Negative

Rating definitions - Standby: Applicable for supplying emergency power for the duration of the utility power outage. No overload capability is available for this rating. (All ratings in accordance with BS5514, ISO3046 and DIN6271). Prime (Unlimited Running Time): Applicable for supplying electric power in lieu of commercially purchased power. Prime power is the maximum power available at variable load. A 10% overload capacity is available for 1 hour in 12 hours. (All ratings in accordance with BS5514, ISO3046, ISO8528 and DIN6271).

SD040/050

OPERATING DATA

	STANDBY				PRIME			
	SD040		SD050		SD040		SD050	
GENERATOR OUTPUT VOLTAGE/KW-60Hz	Rated AMP		Rated AMP		Rated AMP		Rated AMP	
120/240V, 1-phase, 1.0 pf	40	167	50	208	32	133	40	167
120/208V, 3-phase, 0.8 pf	40	139	50	174	32	111	40	139
120/240V, 3-phase, 0.8 pf	40	120	50	151	32	96	40	120
277/480V, 3-phase, 0.8 pf	40	60	50	75	32	48	40	60
600V, 3-phase, 0.8 pf	40	48	50	60	32	39	40	48
	NOTE: Consult your Generac dealer for additional voltages.							
GENERATOR OUTPUT VOLTAGE/KVA-50Hz	Rated AMP		Rated AMP		Rated AMP		Rated AMP	
110/220V, 1-phase, 1.0 pf	32	146	40	182	26	116	33	149
115/200V, 3-phase, 0.8 pf	40	116	50	145	32	93	40	115
100/200V, 3-phase, 0.8 pf	40	116	50	145	32	93	40	115
231/400V, 3-phase, 0.8 pf	40	58	50	72	32	46	40	58
480V, 3-phase, 0.8 pf	40	48	50	60	32	39	40	48
	NOTE: Consult your Generac dealer for additional voltages.							
MOTOR STARTING KVA								
Maximum at 35% instantaneous voltage dip with standard alternator - 50/60Hz	231/240	400/480V	231/240V	400/480V	231/240V	400/480V	231/240V	400/480V
with optional alternator - 50/60Hz	67/80	76/91	83/100	94/113	67/80	76/91	83/100	94/113
	175/210	212/254	175/210	212/254	175/210	212/254	175/210	212/254
FUEL								
Fuel consumption—60 Hz	25%	50%	75%	100%	25%	50%	75%	100%
Load gal./hr.	1.0	1.8	2.6	3.4	1.27	2.36	3.44	4.52
liters/hr.	3.9	7.0	10.0	12.6	4.83	8.97	13.1	17.2
Fuel consumption—50 Hz	0.91	1.5	2.2	2.8	1.06	1.92	2.79	3.66
gal./hr.	3.5	5.9	8.2	10.8	4.03	7.30	10.6	13.9
liters/hr.	3.1	5.2	7.4	9.2	3.34	6.00	8.36	11.2
Fuel pump lift meters (in.)	0.9 (36)		1.0 (40)		0.9 (36)		1.0 (40)	
COOLING								
Coolant capacity System - lit. (US gal.)	14.6 (3.8)		14.6 (3.8)		14.6 (3.8)		14.6 (3.8)	
Engine - lit. (US gal.)	8.5 (2.24)		8.5 (2.24)		8.5 (2.24)		8.5 (2.24)	
Radiator - lit. (US gal.)	6.1 (1.6)		6.1 (1.6)		6.1 (1.6)		6.1 (1.6)	
Coolant flow/min. 60 Hz - lit. (US gal.)	65 (17.2)		65 (17.2)		65 (17.2)		65 (17.2)	
50 Hz - lit. (US gal.)	50 (13.2)		50 (13.2)		50 (13.2)		50 (13.2)	
Heat rejection to coolant BTU/hr.	146,300		201,670		117,050		165,000	
Inlet air 60 Hz - m ³ /min. (cfm)	122 (4330)		128 (4500)		122 (4330)		128 (4500)	
50 Hz - m ³ /min. (cfm)	102 (3608)		107 (3800)		102 (3608)		107 (3800)	
Max. operating air temp onto radiator *see note °C (°F)	60 (140)		60 (140)		60 (140)		60 (140)	
Max. operating ambient temp *see note °C (°F)	50 (122)		50 (122)		50 (122)		50 (122)	
COMBUSTION AIR REQUIREMENTS								
Flow at rated power 60 Hz - m ³ /min. (cfm)	3.5 (122)		3.7 (132)		2.7 (95)		3.7 (132)	
50 Hz - m ³ /min. (cfm)	2.8 (98)		3.0 (107)		2.2 (76)		3.0 (107)	
EXHAUST								
Exhaust flow at rated output 60 Hz - m ³ /min. (cfm)	9.5 (330)		10.2 (357)		7.3 (257)		10.2 (357)	
50 Hz - m ³ /min. (cfm)	7.5 (265)		8.0 (279)		5.8 (205)		8.0 (279)	
Max recommended back pressure Kpa(Hg)	5 (1.5 ")		5 (1.5 ")		5 (1.5 ")		5 (1.5 ")	
Exhaust temp at rated output °C(°F)	565 (1050)		572 (1062)		537 (1000)		531 (988)	
Exhaust outlet size N.P.T. (female)	2.5"		2.5"		2.5"		2.5"	
ENGINE								
Rated RPM 60 / 50 Hz	1800 / 1500		1800 / 1500		1800 / 1500		1800 / 1500	
HP at rated KW 60 / 50 Hz	63 / 49		81 / 63		49 / 40		63 / 49	
Piston speed 60 Hz m/min. (ft./min.)	360 (1182)		360 (1182)		360 (1182)		360 (1182)	
50 Hz m/min. (ft./min.)	300(985)		300 (985)		300 (985)		300 (985)	
BMEP 60 / 50 Hz - psi	139 / 134		166 / 160		111 / 107		135 / 130	
POWER ADJUSTMENT FOR AMBIENT CONDITIONS								
Temperature								
4.5% for every 10°C above - °C	40		40		40		40	
2.5% for every 10°F above - °F	104		104		104		104	
Altitude								
0.8% for every 300 m above - m	1523		1067		1523		1067	
2.5% for every 1000 ft. above - ft.	5000		3500		5000		3500	

* Note: Values given are maximum temperatures to which power adjustments can be applied. Consult your Generac Power Systems representative if operating conditions exceed these maximums.

STANDARD ENGINE & SAFETY FEATURES

SD040/050

- High Coolant Temperature Automatic Shutdown
- Low Coolant Level Automatic Shutdown
- Low Oil Pressure Automatic Shutdown
- Overspeed Automatic Shutdown (Solid-state)
- Crank Limiter (Solid-state)
- Oil Drain Extension
- Radiator Drain Extension
- Factory-Installed Cool Flow Radiator
- Closed Coolant Recovery System
- UV/Ozone Resistant Hoses
- Rubber-Booted Engine Electrical Connections
- Secondary Fuel Filter
- Fuel Lockoff Solenoid
- Stainless Steel Flexible Exhaust Connection
- Battery Charge Alternator
- Battery Cables
- Battery Tray
- Vibration Isolation of Unit to Mounting Base
- 24 Volt, Solenoid-activated Starter Motor
- Air Cleaner
- Fan Guard
- Control Console
- Air Duct Adaptor
- Engine Block Heater

OPTIONS

OPTIONAL COOLING SYSTEM ACCESSORIES

- Coolant Heater 208/240V

OPTIONAL FUEL ACCESSORIES

- Flexible Fuel Lines
- UL Listed Fuel Tanks
- Base Tank Low Fuel Alarm
- Primary Fuel Filter
- Primary Fuel Filter with Heater

OPTIONAL EXHAUST ACCESSORIES

- Critical Exhaust Silencer (Std. on enclosed gensets)

OPTIONAL ELECTRICAL ACCESSORIES

- Battery, 12 Volt, 90 A.H., 27F (2 req'd)
- 2A Battery Charger
- 10A Dual Rate Battery Charger
- Battery Heater

OPTIONAL ALTERNATOR ACCESSORIES

- Alternator Upsizing
- Alternator Strip Heater
- Alternator Tropicalization
- Voltage Changeover Switch
- Main Line Circuit Breaker

CONTROL CONSOLE OPTIONS

- Analog Control "C" Panel (Bulletin 0151160SBY)
- Analog/Digital Control "E" Panel (Bulletin 0161310SBY)

ADDITIONAL OPTIONAL EQUIPMENT

- Automatic Transfer Switch
- Isochronous Governor
- 3 Light Remote Annunciator
- 5 Light Remote Annunciator
- 20 Light Remote Annunciator
- Remote Relay Panels
- Road Ready Trailer
- Unit Vibration Isolators (Pad/Spring)
- Oil Make-Up System
- Oil Heater
- 5 Year Warranties
- Export Boxing
- GenLink® Communications Software

OPTIONAL ENCLOSURES

- Weather Protective
- Sound Attenuated
- Aluminum and Stainless Steel
- Enclosed Muffler

Distributed by:

Design and specifications subject to change without notice. Dimensions shown are approximate. Contact your Generac dealer for certified drawings. DO NOT USE THESE DIMENSIONS FOR INSTALLATION PURPOSES.

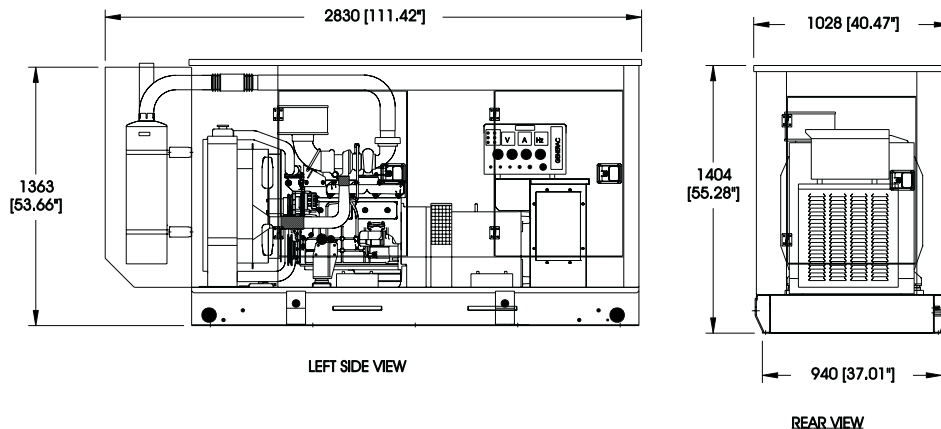

mm [IN]

GENERAC POWER SYSTEMS, INC. • P.O. BOX 8 • WAUKESHA, WI 53187

262/544-4811 • FAX 262/544-4851