

# SD230 SD250

## Liquid Cooled Diesel Engine Generator Sets

### Standby Power Rating

230KW 60Hz / 230KVA 50Hz

250KW 60Hz / 250KVA 50Hz

### Prime Power Rating

185KW 60Hz / 185KVA 50Hz

205KW 60Hz / 205KVA 50Hz

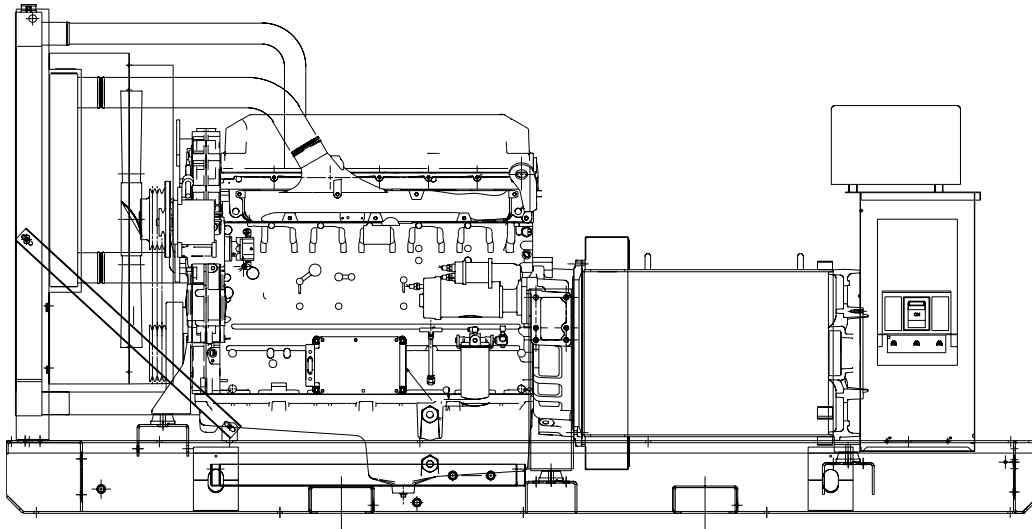

Power Matched

**DDC 12.7 DTA ENGINE**

Turbocharged / Aftercooled

**DETROIT DIESEL  
POWERED**

## FEATURES

- **INNOVATIVE DESIGN & PROTOTYPE TESTING** are key components of GENERAC'S success in "IMPROVING POWER BY DESIGN." But it doesn't stop there. Total commitment to component testing, reliability testing, environmental testing, destruction and life testing, plus testing to applicable CSA, NEMA, EGSA, and other standards, allows you to choose GENERAC POWER SYSTEMS with the confidence that these systems will provide superior performance.
- **TEST CRITERIA:**
  - ✓ PROTOTYPE TESTED
  - ✓ SYSTEM TORSIONAL TESTED
  - ✓ ELECTRO-MAGNETIC INTERFERENCE
  - ✓ NEMA MG-1 EVALUATION
  - ✓ MOTOR STARTING ABILITY
  - ✓ SHORT CIRCUIT TESTING
  - ✓ UL 2200 COMPLIANCE AVAILABLE
- **SOLID-STATE, FREQUENCY COMPENSATED VOLTAGE REGULATION.** This state-of-the-art power maximizing regulation

system is standard on all Generac models. It provides optimized FAST RESPONSE to changing load conditions and MAXIMUM MOTOR STARTING CAPABILITY by electronically torque-matching the surge loads to the engine.

- **SINGLE SOURCE SERVICE RESPONSE** from Generac's dealer network provides parts and service know-how for the entire unit, from the engine to the smallest electronic component. You are never on your own when you own a GENERAC POWER SYSTEM.
- **ECONOMICAL DIESEL POWER.** Low cost operation due to modern diesel engine technology. Better fuel utilization plus lower cost per gallon provide real savings.
- **GENERAC TRANSFER SWITCHES, SWITCHGEAR AND ACCESSORIES.** Long life and reliability is synonymous with GENERAC POWER SYSTEMS. One reason for this confidence is that the GENERAC product line includes its own transfer systems, accessories, switchgear and controls for total system compatibility.

# GENERAC®

---

## POWER SYSTEMS, INC.

# APPLICATION & ENGINEERING DATA

SD230/SD250

## GENERATOR SPECIFICATIONS

TYPE .....	Four-pole, revolving field
ROTOR INSULATION .....	Class H
STATOR INSULATION .....	Class H
LINE-TO-LINE HARMONIC FACTOR .....	5%
BALANCED TELEPHONE INFLUENCE FACTOR (TIF) .....	<50
ALTERNATOR .....	Self-ventilated and drip-proof
BEARINGS (PRE-LUBED & SEALED) .....	1
COUPLING .....	Direct, Flexible Disc
LOAD CAPACITY (STANDBY) .....	100%
LOAD CAPACITY (PRIME) .....	110%

**NOTE: Emergency loading in compliance with NFPA 99, NFPA 110, paragraph 5-13.2.6. Generator rating and performance in accordance with ISO8528-5, BS5514, SAE J1349, ISO3046 and DIN6271 standards.**

### EXCITATION SYSTEM

PERMANENT MAGNET EXCITER (standard) .....	±0.25% regulation ✓
Enhances motor starting capabilities .....	✓
Isolates the excitation system from non-linear loads .....	✓
Sustains short circuit current (300% for 10 seconds) .....	✓
Mounted outboard of main bearing (for easy maintenance) .....	✓
REGULATION .....	Solid-state ✓

## GENERATOR FEATURES

- Four pole, revolving field generator, directly connected to the engine shaft through a heavy-duty, flexible disc for permanent alignment.
- Generator meets the temperature rise standards for class "F" insulation as defined by NEMA MG1-32.6, while the insulation system meets the requirements for the higher class "H" rating.
- All prototype models have passed a three-phase symmetrical short circuit test to assure system protection and reliability.
- All prototype models are tested for motor starting ability by measuring the instantaneous voltage dip with a waveform data acquisition system.
- All models utilize an advanced wire harness design for reliable interconnection within the circuitry.
- Magnetic circuit, including amortisseur windings, tooth and skewed stator design, provides a minimal level of waveform distortion and an electromagnetic interference level which meets accepted requirements for standard AM radio, TV, and marine radio telephone applications.
- Voltage waveform deviation, total harmonic content of the AC waveform, and T.I.F. (Telephone Influence Factor) have been evaluated to acceptable standards in accordance with NEMA MG1-32.
- Alternator is self-ventilated and drip-proof constructed.
- Fully life-tested protective systems, including "field circuit and thermal overload protection" and optional main-line circuit breakers capable of handling full output capacity.
- System Torsional acceptability confirmed during Prototype Testing.

## ENGINE SPECIFICATIONS

MAKE .....	Detroit Diesel
MODEL .....	Series 60, 4-Cycle
CYLINDERS .....	6-Inline
DISPLACEMENT - liter/(in <sup>3</sup> ) .....	12.7 (778)
BORE - mm/(in.) .....	130 (5.12)
STROKE - mm/(in.) .....	160 (6.30)
COMPRESSION RATIO .....	15.0:1
INTAKE AIR .....	Turbocharged/Aftercooled
NUMBER OF MAIN BEARINGS .....	7, Precision Half-Shell
CONNECTING RODS .....	I-Section, Forged Steel (SAE 4140)
CYLINDER HEAD .....	Slab, 4-Valve
PISTONS .....	Articulated / Oil Cooled
CRANKSHAFT .....	Induction Hardened, Forged Steel

### VALVE TRAIN

LIFTER TYPE .....	Roller Follower
-------------------	-----------------

### ENGINE GOVERNOR

TYPE .....	DDEC IV Electronic Control
ELECTRONIC / ISOCHRONOUS .....	Standard
STEADY STATE FREQUENCY REGULATION .....	±0.25%

### LUBRICATION SYSTEM

TYPE .....	Full Pressure
OIL FILTER .....	Full Flow Cartridge and Bypass
OIL PAN CAPACITY WITH FILTERS - liter/(qt.) .....	36.0 (38.0)

### COOLING SYSTEM

TYPE OF SYSTEM .....	Pressurized, Closed Recovery
WATER PUMP TYPE .....	Centrifugal
TYPE OF FAN .....	Pusher
NUMBER OF FAN BLADES .....	7
DIAMETER OF FAN - mm/(in.) .....	914 (36.0)
COOLANT HEATER .....	120V(1800W)

### FUEL SYSTEM

FUEL .....	No. 2 Diesel Fuel
	(Fuel should conform to ASTM Spec.)
FUEL FILTER .....	Paper Element Type
FUEL LINE (Supply) .....	1/2" FNPT
FUEL RETURN LINE .....	1/2" FNPT

### ELECTRICAL SYSTEM

BATTERY CHARGE ALTERNATOR .....	30 Amps at 24V
STARTER MOTOR .....	24V
RECOMMENDED BATTERY .....	2 x 12V
GROUND POLARITY .....	Negative

Rating definitions - Standby: Applicable for supplying emergency power for the duration of the utility power outage. No overload capability is available for this rating. (All ratings in accordance with BS5514, ISO3046 and DIN6271). Prime (Unlimited Running Time): Applicable for supplying electric power in lieu of commercially purchased power. Prime power is the maximum power available at variable load. A 10% overload capacity is available for 1 hour in 12 hours. (All ratings in accordance with BS5514, ISO3046, ISO8528 and DIN6271).

**SD230/SD250**

OPERATING DATA	STANDBY				PRIME			
	SD230		SD250		SD230		SD250	
<b>GENERATOR OUTPUT VOLTAGE/KW-60Hz</b>	<b>kW</b>	<b>Rated AMP</b>	<b>kW</b>	<b>Rated AMP</b>	<b>kW</b>	<b>Rated AMP</b>	<b>kW</b>	<b>Rated AMP</b>
120/208V, 3-phase, 0.8 pf	230	799	250	868	185	642	205	711
120/240V, 3-phase, 0.8 pf	230	692	250	753	185	556	205	616
277/480V, 3-phase, 0.8 pf	230	346	250	376	185	278	205	308
600V, 3-phase, 0.8 pf	230	277	250	301	185	223	205	247
<b>GENERATOR OUTPUT VOLTAGE/KVA-50Hz</b>	<b>kVA</b>	<b>Rated AMP</b>	<b>kVA</b>	<b>Rated AMP</b>	<b>kVA</b>	<b>Rated AMP</b>	<b>kVA</b>	<b>Rated AMP</b>
115/200V, 3-phase, 0.8 pf	230	664	250	722	185	534	205	591
100/200V, 3-phase, 0.8 pf	230	664	250	722	185	534	205	591
231/400V, 3-phase, 0.8 pf	230	332	250	360	185	267	205	295
480V, 3-phase, 0.8 pf	230	277	250	301	185	222	205	246
<b>MOTOR STARTING KVA</b> Maximum at 35% instantaneous voltage dip with standard alternator; 50/60 Hz with optional alternator; 50/60 Hz	<b>220/240V</b>	<b>400/480V</b>	<b>220/240V</b>	<b>400/480V</b>	<b>220/240V</b>	<b>400/480V</b>	<b>220/240V</b>	<b>400/480V</b>
	566/680	792/950	566/680	792/950	566/680	792/950	566/680	792/950
	800/960	1116/1340	800/960	1116/1340	800/960	1116/1340	800/960	1116/1340
<b>FUEL</b>								
Fuel consumption—60 Hz	% Load	<b>25%</b> <b>50%</b> <b>75%</b> <b>100%</b>	<b>25%</b> <b>50%</b> <b>75%</b> <b>100%</b>	<b>25%</b> <b>50%</b> <b>75%</b> <b>100%</b>	<b>25%</b> <b>50%</b> <b>75%</b> <b>100%</b>	<b>25%</b> <b>50%</b> <b>75%</b> <b>100%</b>	<b>25%</b> <b>50%</b> <b>75%</b> <b>100%</b>	<b>25%</b> <b>50%</b> <b>75%</b> <b>100%</b>
	gal./hr.	5.3 9.6 13.6 17.4	5.7 10.4 14.5 18.6	4.8 8.5 12.1 16.0	5.3 9.3 13.2 17.4	4.8 8.5 12.1 16.0	5.3 9.3 13.2 17.4	4.8 8.5 12.1 16.0
	liters/hr.	20.1 36.3 51.4 65.9	21.6 39.4 54.9 70.4	18.2 32.2 45.8 60.6	20.1 35.2 50.0 65.9	18.2 32.2 45.8 60.6	20.1 35.2 50.0 65.9	18.2 32.2 45.8 60.6
Fuel consumption—50 Hz	% Load	<b>25%</b> <b>50%</b> <b>75%</b> <b>100%</b>	<b>25%</b> <b>50%</b> <b>75%</b> <b>100%</b>	<b>25%</b> <b>50%</b> <b>75%</b> <b>100%</b>	<b>25%</b> <b>50%</b> <b>75%</b> <b>100%</b>	<b>25%</b> <b>50%</b> <b>75%</b> <b>100%</b>	<b>25%</b> <b>50%</b> <b>75%</b> <b>100%</b>	<b>25%</b> <b>50%</b> <b>75%</b> <b>100%</b>
	gal./hr.	4.7 8.4 12.2 15.9	5.0 8.9 12.9 16.9	4.1 7.4 10.5 13.8	4.6 8.3 11.8 15.5	4.1 7.4 10.5 13.8	4.6 8.3 11.8 15.5	4.1 7.4 10.5 13.8
	liters/hr.	17.8 31.8 46.2 60.2	18.9 33.7 48.8 64.0	15.5 28.0 39.8 52.2	17.4 31.4 44.7 58.7	15.5 28.0 39.8 52.2	17.4 31.4 44.7 58.7	15.5 28.0 39.8 52.2
Fuel pump lift	in.	80	80	80	80	80	80	80
<b>COOLING</b>								
Coolant capacity	System - lit./gal.	40.9 (10.8)	40.9 (10.8)	40.9 (10.8)	40.9 (10.8)	40.9 (10.8)	40.9 (10.8)	40.9 (10.8)
	Engine - lit./gal.	22.7 (6.0)	22.7 (6.0)	22.7 (6.0)	22.7 (6.0)	22.7 (6.0)	22.7 (6.0)	22.7 (6.0)
	Radiator - lit./gal.	18.2 (4.8)	18.2 (4.8)	18.2 (4.8)	18.2 (4.8)	18.2 (4.8)	18.2 (4.8)	18.2 (4.8)
Coolant flow/min.	60 Hz - lit./gal.	363 (96.0)	363 (96.0)	363 (96.0)	363 (96.0)	363 (96.0)	363 (96.0)	363 (96.0)
Coolant flow/min.	50 Hz - lit./gal.	303 (80.0)	303 (80.0)	303 (80.0)	303 (80.0)	303 (80.0)	303 (80.0)	303 (80.0)
Heat rejection to coolant	60 Hz - BTU/hr.	369,000	402,000	342,000	342,000	342,000	342,000	342,000
	50 Hz - BTU/hr.	372,000	387,000	336,000	348,000	336,000	348,000	336,000
Inlet air	60 Hz - m <sup>3</sup> /min. (cfm)	680 (24,000)	680 (24,000)	680 (24,000)	680 (24,000)	680 (24,000)	680 (24,000)	680 (24,000)
	50 Hz - m <sup>3</sup> /min. (cfm)	566 (20,000)	566 (20,000)	566 (20,000)	566 (20,000)	566 (20,000)	566 (20,000)	566 (20,000)
Max. air temp. onto radiator	°C (°F)	50 (122)	50 (122)	50 (122)	50 (122)	50 (122)	50 (122)	50 (122)
Max. ambient temperature	°C (°F)	54 (130)	54 (130)	54 (130)	54 (130)	54 (130)	54 (130)	54 (130)
Max. external pressure drop on radiator	in. H <sub>2</sub> O	1.0	1.0	1.0	1.0	1.0	1.0	1.0
<b>COMBUSTION AIR REQUIREMENTS</b>								
Flow at rated power	60 Hz - m <sup>3</sup> /min. (cfm)	25.9 (915)	27.8 (982)	23.8 (840)	24.9 (879)	23.8 (840)	24.9 (879)	23.8 (840)
	50 Hz - m <sup>3</sup> /min. (cfm)	22.8 (805)	23.5 (830)	21.2 (749)	21.9 (773)	21.2 (749)	21.9 (773)	21.2 (749)
<b>EXHAUST</b>								
Exhaust flow at rated output								
	60 Hz - m <sup>3</sup> /min. (cfm)	62.2 (2197)	67.7 (2390)	54.8 (1936)	57.9 (2043)	54.8 (1936)	57.9 (2043)	54.8 (1936)
	50 Hz - m <sup>3</sup> /min. (cfm)	54.7 (1932)	57.2 (2019)	49.7 (1756)	51.7 (1827)	49.7 (1756)	51.7 (1827)	49.7 (1756)
Maximum recommended back pressure	Kpa ("Hg)	10.2 (3.0)	10.2 (3.0)	10.2 (3.0)	10.2 (3.0)	10.2 (3.0)	10.2 (3.0)	10.2 (3.0)
Exhaust temperature at rated output	°C (°F)	418 (784)	427 (801)	403 (759)	407 (765)	403 (759)	407 (765)	403 (759)
Exhaust outlet size	mm. (in)	127 (5.0)	127 (5.0)	127 (5.0)	127 (5.0)	127 (5.0)	127 (5.0)	127 (5.0)
<b>ENGINE</b>								
Rated RPM	60 Hz / 50 Hz	1800 / 1500	1800 / 1500	1800 / 1500	1800 / 1500	1800 / 1500	1800 / 1500	1800 / 1500
HP at rated KW	60 Hz / Hz	415 / 365	455 / 390	359 / 314	392 / 355	359 / 314	392 / 355	359 / 314
Piston speed	60 Hz - m/sec. (ft./min)	9.6 (1890)	9.6 (1890)	9.6 (1890)	9.6 (1890)	9.6 (1890)	9.6 (1890)	9.6 (1890)
	50 Hz - m/sec. (ft./min)	8.0 (1575)	8.0 (1575)	8.0 (1575)	8.0 (1575)	8.0 (1575)	8.0 (1575)	8.0 (1575)
BMEP	60 Hz / 50 Hz - psi	235 / 248	257 / 265	203 / 169	222 / 241	203 / 169	222 / 241	203 / 169
<b>POWER ADJUSTMENT FOR AMBIENT CONDITIONS</b>								
Temperature								
	-1% for every 5.5°C above - C°	40	40	40	40	40	40	40
	-1% for every 10°F above - F°	104	104	104	104	104	104	104
Altitude								
	-1.5% for every 305 m above - m	2286	2103	2286	2103	2286	2103	2286
	-1.5% for every 1000 ft. above - ft.	7500	6900	7500	6900	7500	6900	7500

# STANDARD ENGINE & SAFETY FEATURES

SD230/SD250

- High Coolant Temperature Automatic Shutdown
- Low Coolant Level Automatic Shutdown
- Low Oil Pressure Automatic Shutdown
- Overspeed Automatic Shutdown (Solid-state)
- Crank Limiter (Solid-state)
- Oil Drain Extension
- Radiator Drain
- Factory-Installed Cool Flow Radiator
- Closed Coolant System
- UV/Ozone Resistant Hoses
- Rubber-Booted Engine Electrical Connections
- Stainless Steel Flexible Exhaust Connection
- Battery Charge Alternator
- Battery Cables
- Battery Tray
- Vibration Isolation between Unit Base and Structure
- 24 Volt, Solenoid-activated Starter Motor
- Air Cleaner
- Fan Guard
- Control Console
- Isochronous Governor
- Jacket Water Heater
- Radiator Duct Adaptor

## CONTROL CONSOLE

- **STANDARD "E" CONTROL PANEL** (see bulletin #0161310SBY) The "E" control panel is programmable engine control and monitoring system. It allows the user to customize the generator starting and running sequence, monitor engine parameters and configure the alarms. This can be done either through its own LCD display and keypad, or using a PC and RS232 or RS485 serial communications.

## OPTIONS

### ■ OPTIONAL COOLING SYSTEM ACCESSORIES

- Radiator Duct Adapter

### ■ OPTIONAL FUEL ACCESSORIES

- Base Tank Low Fuel Alarm
- Primary Fuel Filters
- UL Listed Fuel Tanks
- Electric Fuel Transfer Pump System

### ■ OPTIONAL ELECTRICAL ACCESSORIES

- 10A Dual Rate Battery Charger
- Battery, 24 Volt
- Battery Warmer

### ■ OPTIONAL ALTERNATOR ACCESSORIES

- Alternator Upsizing
- Alternator Heater
- Main Line Circuit Breaker

### ■ OPTIONAL ENCLOSURES

- Weather Protective
- Sound Attenuated
- Aluminum and Stainless Steel
- Enclosed Muffler

### ■ OPTIONAL EXHAUST ACCESSORIES

- Critical Exhaust Silencer

### ■ ADDITIONAL OPTIONAL EQUIPMENT

- Automatic Transfer Switch
- 20 Light Remote Annunciator
- Remote Relay Panels
- Oil Make-Up System
- Oil Heater
- 5 Year Warranties
- Export Boxing
- GenLink® Communications Software

Distributed by:

Design and specifications subject to change without notice. Dimensions shown are approximate. Contact your Generac dealer for certified drawings. DO NOT USE THESE DIMENSIONS FOR INSTALLATION PURPOSES.

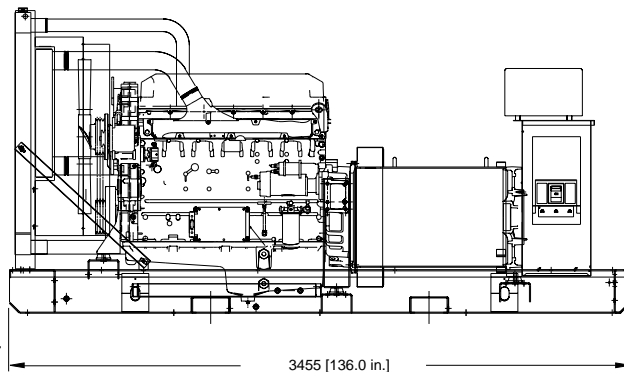
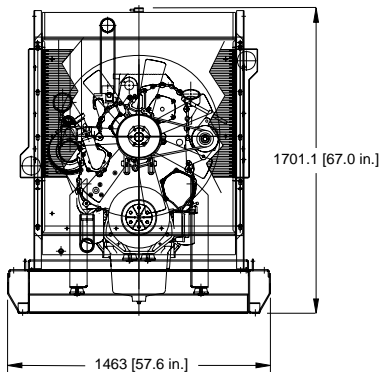

mm [in]

DRY WEIGHT: 6000lbs.

GENERAC® POWER SYSTEMS, INC. • P.O. BOX 8 • WAUKESHA, WI 53187

262/544-4811 • FAX 262/544-0770