

# SD130 SD150

## Liquid Cooled Diesel Engine Generator Sets

### Standby Power Rating

130KW 60Hz/130KVA 50 Hz

150KW 60 Hz/150KVA 50 Hz

### Prime Power Rating

105KW 60 Hz/105KVA 50 Hz

123KW 60 Hz/123KVA 50 Hz

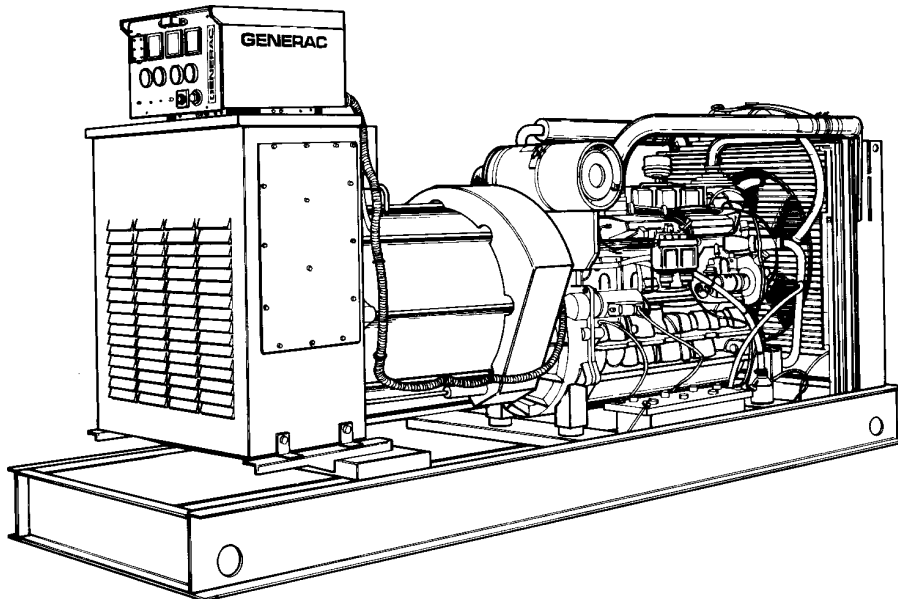

Power Matched

**GENERAC 7.5DMTAE ENGINE**

Turbo-Charged, Aftercooled

## FEATURES

- **INNOVATIVE DESIGN & PROTOTYPE TESTING** are key components of GENERAC'S success in "IMPROVING POWER BY DESIGN." But it doesn't stop there. Total commitment to component testing, reliability testing, environmental testing, destruction and life testing, plus testing to applicable CSA, NEMA, EGSA, and other standards, allows you to choose GENERAC POWER SYSTEMS with the confidence that these systems will provide superior performance.
- **TEST CRITERIA:**
  - ✓ PROTOTYPE TESTED
  - ✓ SYSTEM TORSIONAL TESTED
  - ✓ ELECTRO-MAGNETIC INTERFERENCE
  - ✓ NEMA MG1 EVALUATION
  - ✓ MOTOR STARTING ABILITY
  - ✓ SHORT CIRCUIT TESTING
  - ✓ UL 2200 COMPLIANCE AVAILABLE
- **SOLID-STATE, FREQUENCY COMPENSATED VOLTAGE REGULATION.** This state-of-the-art power maximizing regulation system is standard on all Generac models. It provides optimized
- FAST RESPONSE to changing load conditions and MAXIMUM MOTOR STARTING CAPABILITY by electronically torque-matching the surge loads to the engine.
- **SINGLE SOURCE SERVICE RESPONSE** from Generac's dealer network provides parts and service know-how for the entire unit, from the engine to the smallest electronic component. You are never on your own when you own a GENERAC POWER SYSTEM.
- **ECONOMICAL DIESEL POWER.** Low cost operation due to modern diesel engine technology. Better fuel utilization plus lower cost per gallon provide real savings.
- **LONGER ENGINE LIFE.** Generac heavy-duty diesels provide long and reliable operating life.
- **GENERAC TRANSFER SWITCHES AND ACCESSORIES.** Long life and reliability is synonymous with GENERAC POWER SYSTEMS. One reason for this confidence is that the GENERAC product line includes its own transfer systems, accessories, and controls for total system compatibility.

# GENERAC®

---

## POWER SYSTEMS, INC.

# APPLICATION & ENGINEERING DATA

SD130/SD150

## GENERATOR SPECIFICATIONS

TYPE .....	Four-pole, revolving field
ROTOR INSULATION .....	Class H
STATOR INSULATION .....	Class H
TOTAL HARMONIC DISTORTION .....	<3.0%
TELEPHONE INFLUENCE FACTOR (TIF) .....	<50
ALTERNATOR .....	Self-ventilated and drip-proof
BEARINGS (PRE-LUBED & SEALED) .....	2
COUPLING .....	Flexible Disc
LOAD CAPACITY (STANDBY) .....	100%

**NOTE: Emergency loading in compliance with NFPA 99, NFPA 110, paragraph 5-13.2.6. Generator rating and performance in accordance with ISO8528-5, BS5514, SAE J1349, ISO3046 and DIN6271 standards.**

### EXCITATION SYSTEM

PERMANENT MAGNET PILOT EXCITER .....	Eighteen-pole exciter ✓
	Magnetically coupled DC current ✓
	Mounted outboard of main bearing ✓
REGULATION .....	Solid-state ✓
	±1% regulation ✓

## GENERATOR FEATURES

- Four pole, revolving field generator, directly connected to the engine shaft through a heavy-duty, flexible disc for permanent alignment.
- Generator meets the temperature rise standards for class "F" insulation as defined by NEMA MG1-32.6, while the insulation system meets the requirements for the higher class "H" rating.
- All prototype models have passed a three-phase symmetrical short circuit test to assure system protection and reliability.
- All prototype models are tested for motor starting ability by measuring the instantaneous voltage dip with a waveform data acquisition system.
- All models utilize an advanced wire harness design for reliable interconnection within the circuitry.
- Magnetic circuit, including amortisseur windings, tooth and skewed stator design, provides a minimal level of waveform distortion and an electromagnetic interference level which meets accepted requirements for standard AM radio, TV, and marine radio telephone applications.
- Voltage waveform deviation, total harmonic content of the AC waveform, and T.I.F. (Telephone Influence Factor) have been evaluated to acceptable standards in accordance with NEMA MG1-32.
- Alternator is self-ventilated and drip-proof constructed.
- Fully life-tested protective systems, including "field circuit and thermal overload protection" and optional main-line circuit breakers capable of handling full output capacity.
- System Torsional acceptability confirmed during Prototype Testing.

## ENGINE SPECIFICATIONS

MAKE .....	GENERAC
MODEL .....	7.5DMTA
CYLINDERS .....	6 in-line
DISPLACEMENT .....	7.5 Liters (457 cu. in.)
BORE .....	118 mm (4.64 in.)
STROKE .....	115 mm (4.52 in.)
COMPRESSION RATIO .....	16:1
INTAKE AIR .....	Turbocharged, Aftercooled
NUMBER OF MAIN BEARINGS .....	7
CONNECTING RODS .....	6-Carbon Steel
CYLINDER HEAD .....	Cast Iron with Overhead Valve
PISTONS .....	6-Heat Resistant Aluminum Alloy
CRANKSHAFT .....	Case Hardened, Die Forged, Carbon Steel

### VALVE TRAIN

LIFTER TYPE .....	Solid
INTAKE VALVE MATERIAL .....	Special Heat Resistant Steel
EXHAUST VALVE MATERIAL .....	Special Heat Resistant Steel
HARDENED VALVE SEATS .....	Replaceable

### ENGINE GOVERNOR

<input type="checkbox"/> ELECTRONIC .....	Standard
FREQUENCY REGULATION, NO-LOAD TO FULL LOAD ...	0.5%
STEADY STATE REGULATION .....	±0.25%

### LUBRICATION SYSTEM

TYPE OF OIL PUMP .....	Forced Feed Lubrication w/ Oil Pump
OIL FILTER .....	Full Flow, Cartridge
CRANKCASE CAPACITY .....	22.7 Liters (6.0 U.S. gallons)

### COOLING SYSTEM

TYPE OF SYSTEM .....	Pressurized, closed recovery
WATER PUMP .....	Pre-lubed, Self-Sealing
TYPE OF FAN .....	Pusher
NUMBER OF FAN BLADES .....	7
DIAMETER OF FAN .....	650 mm (26.0 in.)
COOLANT HEATER .....	120V, 1800 W

### FUEL SYSTEM

FUEL .....	#2D Fuel (Min Cetane #40)
	(Fuel should conform to ASTM Spec.)
FUEL FILTER .....	10 Micron
FUEL INJECTION PUMP .....	ZEXEL
FUEL PUMP .....	Mechanical
INJECTORS .....	Multi-hole, nozzle type
ENGINE TYPE .....	Direct injection
FUEL LINE (Supply) .....	9.53 mm (0.375 in.)
FUEL RETURN LINE .....	9.53 mm (0.375 in.)

### ELECTRICAL SYSTEM

BATTERY CHARGE ALTERNATOR .....	35 Amps at 24 V
STARTER MOTOR .....	24 V
RECOMMENDED BATTERY .....	2-12V, 135 AH, 4D
GROUND POLARITY .....	Negative

Rating definitions - Standby: Applicable for supplying emergency power for the duration of the utility power outage. No overload capability is available for this rating. (All ratings in accordance with BS5514, ISO3046 and DIN6271). Prime (Unlimited Running Time): Applicable for supplying electric power in lieu of commercially purchased power. Prime power is the maximum power available at variable load. A 10% overload capacity is available for 1 hour in 12 hours. (All ratings in accordance with BS5514, ISO3046, ISO8528 and DIN6271).

**SD130/SD150**

**OPERATING DATA**

	STANDBY				PRIME			
	SD130		SD150		SD130		SD150	
<b>GENERATOR OUTPUT VOLTAGE/KW-60Hz</b>	<b>kW</b>	<b>Rated AMP</b>	<b>kW</b>	<b>Rated AMP</b>	<b>kW</b>	<b>Rated AMP</b>	<b>kW</b>	<b>Rated AMP</b>
120/240V, 1-phase, 1.0 pf	130	542	150	625	105	438	123	513
120/208V, 3-phase, 0.8 pf	130	451	150	520	105	364	123	427
120/240V, 3-phase, 0.8 pf	130	391	150	451	105	316	123	370
277/480V, 3-phase, 0.8 pf	130	195	150	226	105	158	123	185
600V, 3-phase, 0.8 pf	130	156	150	180	105	126	123	148
NOTE: Consult your Generac dealer for additional voltages.								
<b>GENERATOR OUTPUT VOLTAGE/KVA-50Hz</b>	<b>kVA</b>	<b>Rated AMP</b>	<b>kVA</b>	<b>Rated AMP</b>	<b>kVA</b>	<b>Rated AMP</b>	<b>kVA</b>	<b>Rated AMP</b>
110/220V, 1-phase, 1.0 pf	104	472	120	545	84	382	98	445
115/200V, 3-phase, 0.8 pf	130	375	150	433	105	303	123	355
100/200V, 3-phase, 0.8 pf	130	375	150	433	105	303	123	355
231/400V, 3-phase, 0.8 pf	130	188	150	217	105	152	123	178
480V, 3-phase, 0.8 pf	130	156	150	180	105	126	123	118
NOTE: Consult your Generac dealer for additional voltages.								
<b>MOTOR STARTING</b>								
Maximum KVA with 35% instantaneous voltage dip								
with standard alternator; 50/60 Hz	<b>231/240V</b>	<b>400/480V</b>	<b>231/240V</b>	<b>400/480V</b>	<b>231/240V</b>	<b>400/480V</b>	<b>231/240V</b>	<b>400/480V</b>
with optional alternator; 50/60 Hz	234/281	275/331	325/390	338/405	234/281	275/331	325/390	338/405
	417/500	545/690	654/785	910/1092	417/500	545/690	654/785	910/1092
<b>FUEL</b>								
Fuel consumption—60 Hz	<b>25%</b>	<b>50%</b>	<b>75%</b>	<b>100%</b>	<b>25%</b>	<b>50%</b>	<b>75%</b>	<b>100%</b>
Load gal./hr.	3.1	5.9	8.5	11.0	3.4	6.4	9.2	12.0
liters/hr.	11.7	22.3	32.2	41.6	12.9	24.2	34.8	45.4
Fuel consumption—50 Hz	<b>25%</b>	<b>50%</b>	<b>75%</b>	<b>100%</b>	<b>25%</b>	<b>50%</b>	<b>75%</b>	<b>100%</b>
Load gal./hr.	2.5	4.7	6.8	8.8	2.7	5.1	7.4	9.6
liters/hr.	9.4	17.9	25.7	33.3	10.3	19.4	27.9	36.3
	9.4	17.9	25.7	33.3	10.3	19.4	27.9	36.3
	7.5	14.3	20.6	26.6	7.5	14.3	20.6	26.6
	8.2	15.5	22.3	29.1	8.2	15.5	22.3	29.1
<b>COOLING</b>								
Coolant capacity System - lit. (US gal.)	42.4	(11.2)	42.4	(11.2)	42.4	(11.2)	42.4	(11.2)
Engine - lit. (US gal.)	13.0	(3.4)	13.0	(3.4)	13.0	(3.4)	13.0	(3.4)
Radiator - lit. (US gal.)	29.4	(7.8)	29.4	(7.8)	29.4	(7.8)	29.4	(7.8)
Coolant flow/min. 60 Hz - lit. (US gal.)	272.6	(72.0)	272.6	(72.0)	272.6	(72.0)	272.6	(72.0)
50 Hz - lit. (US gal.)	227.2	(60.0)	227.2	(60.0)	227.2	(60.0)	227.2	(60.0)
Heat rejection to coolant BTU/hr.	451,000		477,000		360,800		381,600	
Inlet air 60 Hz - m <sup>3</sup> /min. (cfm)	425.0	(15,000)	425.0	(15,000)	425.0	(15,000)	425.0	(15,000)
50 Hz - m <sup>3</sup> /min. (cfm)	354.0	(12,500)	354.0	(12,500)	354.0	(12,500)	354.0	(12,500)
Max. operating air temp onto radiator								
*see note °C (°F)	60	(140)	60	(140)	60	(140)	60	(140)
Max. operating ambient temp								
*see note °C (°F)	50	(122)	50	(122)	50	(122)	50	(122)
Max. external pressure drop on rad. in. H <sub>2</sub> O	0.5		0.5		0.5		0.5	
<b>COMBUSTION AIR REQUIREMENTS</b>								
Flow at rated power 60 Hz - m <sup>3</sup> /min. (cfm)	12.5	(442.0)	14.5	(512.3)	10.0	(353.6)	11.7	(414.8)
50 Hz - m <sup>3</sup> /min. (cfm)	9.9	(349.1)	11.5	(405.7)	8.0	(279.3)	9.2	(326.407)
<b>EXHAUST</b>								
Exhaust flow at rated output 60 Hz - m <sup>3</sup> /min. (cfm)	36.8	(1301)	42.7	(1508)	28.6	(1009)	33.5	(1184)
50 Hz - m <sup>3</sup> /min. (cfm)	29.1	(1027)	33.8	(1194)	22.6	(797)	26.4	(932)
Max recommended back pressure Kpa (Hg)	5.1	(1.5)	5.1	(1.5)	5.1	(1.5)	5.1	(1.5)
Exhaust temp at rated output °C (°F)	649	(1200)	649	(1200)	621	(1150)	621	(1150)
Exhaust outlet size mm (in)	127	(5.0)	127	(5.0)	127	(5.0)	127	(5.0)
<b>ENGINE</b>								
Rated RPM 60 / 50 Hz	1800 / 1500		1800 / 1500		1800 / 1500		1800 / 1500	
HP at rated kW 60 50 Hz	195 / 154		226 / 179		158 / 124		183 / 144	
Piston speed (mean) 60 Hz - m/sec. (ft./min.)	6.9 (1358)		6.9 (1358)		6.9 (1358)		6.9 (1358)	
50 Hz - m/sec. (ft./min.)	5.7 (1132)		5.7 (1132)		5.75 (1132)		5.75 (1132)	
BMEP 60 / 50 Hz - psi	186 / 177		216 / 205		151 / 142		175 / 165	
<b>DERATION FACTORS</b>								
Temperature								
-4.5% for every 10°C above - °C	40		40		40		40	
-2.5% for every 10°F above - °F	104		104		104		104	
Altitude								
-0.8% for every 100 m above - m	2286		1525		2286		1525	
-2.5% for every 1000 ft. above - ft.	7500		5000		7500		5000	

\* Note: Values given are maximum temperatures to which power adjustments can be applied. Consult your Generac Power Systems representative if operating conditions exceed these maximums.

# STANDARD ENGINE & SAFETY FEATURES

SD130/SD150

- High Coolant Temperature Automatic Shutdown
- Low Coolant Level Automatic Shutdown
- Low Oil Pressure Automatic Shutdown
- Overspeed Automatic Shutdown (Solid-state)
- Crank Limiter (Solid-state)
- Oil Drain Extension
- Radiator Drain Extension
- Factory-Installed Cool Flow Radiator
- Closed Coolant Recovery System
- UV/Ozone Resistant Hoses
- Rubber-Booted Engine Electrical Connections
- Secondary Fuel Filter
- Fuel Lockoff Solenoid
- Stainless Steel Flexible Exhaust Connection
- Battery Charge Alternator
- Battery Cables
- Battery Tray
- Vibration Isolation of Unit to Mounting Base
- 24 Volt, Solenoid-activated Starter Motor
- Air Cleaner
- Fan Guard
- Control Console
- Coolant Heater
- Isochronous Governor
- Radiator Duct Adapter

## OPTIONS

### ■ OPTIONAL COOLING SYSTEM ACCESSORIES

- Coolant Heater 208/240VAC

### ■ OPTIONAL FUEL ACCESSORIES

- Flexible Fuel Lines
- UL Listed Fuel Tanks
- Base Tank Fuel Alarms
- Primary Fuel Filter
- Primary Fuel Filter with Heater

### ■ OPTIONAL EXHAUST ACCESSORIES

- Critical Exhaust Silencer (Standard on enclosed gensets)

### ■ OPTIONAL ELECTRICAL ACCESSORIES

- Battery, 12 Volt, 135 A.H., 4D (2 req'd)
- Battery, 12 Volt, 225 A.H., 8D (2 req'd)
- 2A Battery Charger
- 10A Dual Rate Battery Charger
- Battery Heater

### ■ OPTIONAL ALTERNATOR ACCESSORIES

- Alternator Upsizing
- Alternator Strip Heater
- Alternator Tropicalization
- Voltage Changeover Switch
- Main Line Circuit Breaker

### ■ CONTROL CONSOLE OPTIONS

- Analog Control "C" Panel (Bulletin 0151160SBY)
- Analog/Digital Control "E" Panel (Bulletin 0161310SBY)

### ■ ADDITIONAL OPTIONAL EQUIPMENT

- Automatic Transfer Switch
- 3 Light Remote Annunciator
- 5 Light Remote Annunciator
- 20 Light Remote Annunciator
- Remote Relay Panels
- Unit Vibration Isolators
- Oil Make-Up System
- Oil Heater
- 5 Year Warranties
- Export Boxing
- GenLink® Communications Software

### ■ OPTIONAL ENCLOSURES

- Weather Protective
- Sound Attenuated
- Aluminum and Stainless Steel
- Enclosed Muffler

Distributed by:

Design and specifications subject to change without notice. Dimensions shown are approximate. Contact your Generac dealer for certified drawings. DO NOT USE THESE DIMENSIONS FOR INSTALLATION PURPOSES.

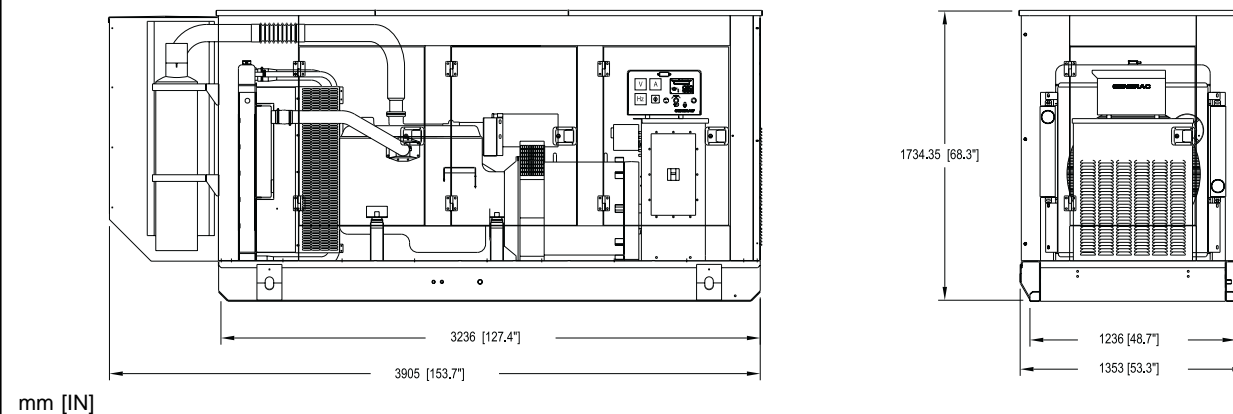

**GENERAC®** POWER SYSTEM, INC. • P.O. BOX 8 • WAUKESHA, WI 53187

262/544-4811 • FAX 262/544-4851