

# SD100

## Liquid Cooled Diesel Engine Generator Sets

Standby Power Rating  
100KW 60 Hz / 100KVA 50 Hz

Prime Power Rating  
80KW 60 Hz / 80KVA 50 Hz

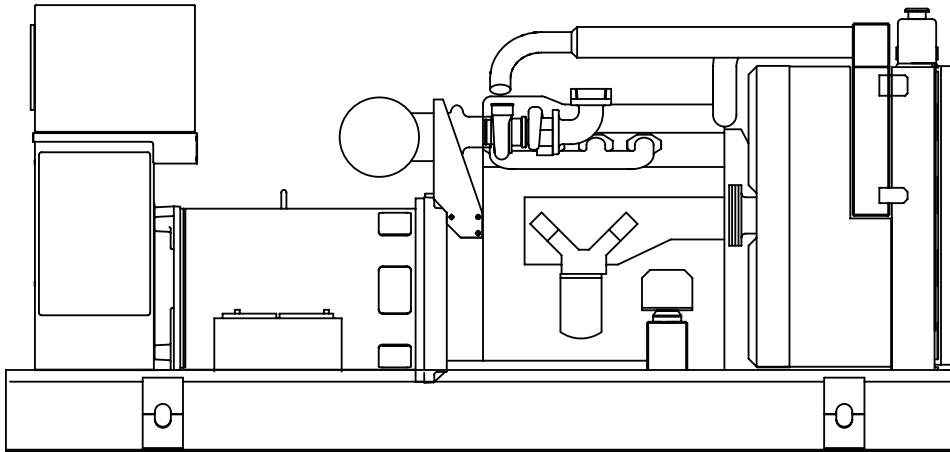

Power Matched  
**GENERAC 3.9DTA ENGINE**  
Turbocharged / Aftercooled

## FEATURES

- **INNOVATIVE DESIGN & PROTOTYPE TESTING** are key components of GENERAC'S success in "IMPROVING POWER BY DESIGN." But it doesn't stop there. Total commitment to component testing, reliability testing, environmental testing, destruction and life testing, plus testing to applicable CSA, NEMA, EGSA, and other standards, allows you to choose GENERAC POWER SYSTEMS with the confidence that these systems will provide superior performance.
- **TEST CRITERIA:**
  - ✓ PROTOTYPE TESTED
  - ✓ SYSTEM TORSIONAL TESTED
  - ✓ ELECTRO-MAGNETIC INTERFERENCE
  - ✓ NEMA MG1 EVALUATION
  - ✓ MOTOR STARTING ABILITY
  - ✓ SHORT CIRCUIT TESTING
  - ✓ UL COMPLIANCE AVAILABLE
- **SOLID-STATE, FREQUENCY COMPENSATED VOLTAGE REGULATION.** This state-of-the-art power maximizing regulation system is standard on all Generac models. It provides optimized
- FAST RESPONSE to changing load conditions and MAXIMUM MOTOR STARTING CAPABILITY by electronically torque-matching the surge loads to the engine.
- **SINGLE SOURCE SERVICE RESPONSE** from Generac's dealer network provides parts and service know-how for the entire unit, from the engine to the smallest electronic component. You are never on your own when you own a GENERAC POWER SYSTEM.
- **ECONOMICAL DIESEL POWER.** Low cost operation due to modern diesel engine technology. Better fuel utilization plus lower cost per gallon provide real savings.
- **LONGER ENGINE LIFE.** Generac heavy-duty diesels provide long and reliable operating life.
- **GENERAC TRANSFER SWITCHES, SWITCHGEAR AND ACCESSORIES.** Long life and reliability is synonymous with GENERAC POWER SYSTEMS. One reason for this confidence is that the GENERAC product line includes its own transfer systems, accessories, switchgear and controls for total system compatibility.

# GENERAC®

## GENERATOR SPECIFICATIONS

TYPE .....	Four-pole, revolving field
ROTOR INSULATION .....	Class H
STATOR INSULATION .....	Class H
TOTAL HARMONIC DISTORTION .....	<3%
TELEPHONE INTERFERENCE FACTOR (TIF) .....	<50
ALTERNATOR .....	Self-ventilated and drip-proof
BEARINGS (PRE-LUBED & SEALED) .....	1
COUPLING .....	Direct, Flexible Disc
LOAD CAPACITY (STANDBY) .....	100%
LOAD CAPACITY (PRIME) .....	110%

**NOTE: Emergency loading in compliance with NFPA 99, NFPA 110. Generator rating and performance in accordance with ISO8528-5, BS5514, SAE J1349, ISO3046 and DIN6271 standards.**

## VOLTAGE REGULATOR

TYPE .....	Full Digital
SENSING .....	3 Phase
REGULATION .....	± 1/4%
FEATURES .....	Built into H-100 Control Panel, V/F Adjustable Adjustable Voltage and Gain

## GENERATOR FEATURES

- Revolving field heavy duty generator
- Quiet drive coupling
- Operating temperature rise 120°C above a 40°C ambient
- Insulation is Class H rated at 150°C rise
- All prototype models have passed three phase short circuit testing

## CONTROL PANEL FEATURES

- TWO FOUR LINE LCD DISPLAYS READ:
  - Voltage (all phases)
  - Power factor
  - kVAR
  - Engine speed
  - Run hours
  - Fault history
  - Coolant temperature
  - Low oil pressure shutdown
  - Overvoltage
  - Low coolant level
  - Exercise speed
  - Not in auto position (flashing light)
  - Current (all phases)
  - kW
  - Transfer switch status
  - Low fuel pressure
  - Service reminders
  - Oil pressure
  - Time and date
  - High coolant temp shutdown
  - Overspeed
  - Low coolant level
  - ATS selection
- INTERNAL FUNCTIONS:
  - I<sup>2</sup>T function for alternator protection from line to neutral and line to line short circuits
  - Emergency stop
  - Programmable auto crank function
  - 2 wire start for any transfer switch
  - Communicates with the Generac HTS transfer switch
  - Built-in 7 day exerciser
  - Adjustable engine speed at exerciser
  - RS232 port for GenLink<sup>®</sup> control
  - RS485 port remote communication
  - Canbus addressable
  - Governor controller and voltage regulator are built into the master control board
  - Temperature range -40°C to 70°C

## ENGINE SPECIFICATIONS

MAKE .....	GENERAC
MODEL .....	3.9DTA
CYLINDERS .....	4 in-line
DISPLACEMENT .....	3.9 Liter (238 cu.in.)
BORE .....	104 mm (4.09 in.)
STROKE .....	115 mm (4.52 in.)
COMPRESSION RATIO .....	16.5:1
INTAKE AIR .....	Turbocharged/Aftercooled
NUMBER OF MAIN BEARINGS .....	5
CONNECTING RODS .....	4-Drop Forged Steel
CYLINDER HEAD .....	Cast Iron Overhead Valve
PISTONS .....	4- Aluminum Alloy
CRANKSHAFT .....	Hardened, Steel

### VALVE TRAIN

LIFTER TYPE .....	Solid
INTAKE VALVE MATERIAL .....	Special Heat Resistant Steel
EXHAUST VALVE MATERIAL .....	Special Heat Resistant Steel
HARDENED VALVE SEATS .....	Replaceable

### ENGINE GOVERNOR

□ ELECTRONIC .....	Standard
FREQUENCY REGULATION, NO-LOAD TO FULL LOAD..	Isosynchronous
STEADY STATE REGULATION .....	±0.25%

### LUBRICATION SYSTEM

TYPE OF OIL PUMP .....	Gear
OIL FILTER .....	Full flow, Cartridge
CRANKCASE CAPACITY .....	18 Litres (19 qts.)
OIL COOLER .....	Oil to water

### COOLING SYSTEM

TYPE OF SYSTEM .....	Pressurized, Closed Recovery
WATER PUMP .....	Pre-Lubed, Self-Sealing
TYPE OF FAN .....	Pusher
NUMBER OF FAN BLADES .....	7
DIAMETER OF FAN .....	457 mm (18 in.)
COOLANT HEATER .....	120V, 1800 W

### FUEL SYSTEM

FUEL .....	#2D Fuel (Min Cetane #40) (Fuel should conform to ASTM Spec.)
FUEL FILTER .....	Single Cartridge
FUEL INJECTION PUMP .....	Stanadyne
FUEL PUMP .....	Mechanical
INJECTORS .....	Multi-Hole, Nozzle Type
ENGINE TYPE .....	Direct Injection
FUEL LINE (Supply) .....	7.94 mm (0.31 in.)
FUEL RETURN LINE .....	6.35 mm (0.25 in.)
STARTING AID .....	Glow Plugs

### ELECTRICAL SYSTEM

BATTERY CHARGE ALTERNATOR .....	30 Amps at 24 V
STARTER MOTOR .....	24 V
RECOMMENDED BATTERY .....	(2)—12 Volt, 90 A.H., 4DLT
GROUND POLARITY .....	Negative

Rating definitions - Standby: Applicable for supplying emergency power for the duration of the utility power outage. No overload capability is available for this rating. (All ratings in accordance with BS5514, ISO3046 and DIN6271). Prime (Unlimited Running Time): Applicable for supplying electric power in lieu of commercially purchased power. Prime power is the maximum power available at variable load. A 10% overload capacity is available for 1 hour in 12 hours. (All ratings in accordance with BS5514, ISO3046, ISO8528 and DIN6271).

## SD100

### OPERATING DATA

	STANDBY SD100		PRIME SD100	
	Rated AMP		Rated AMP	
<b>GENERATOR OUTPUT VOLTAGE/KW-60Hz</b>				
120/240V, 1-phase, 1.0 pf	100	417	80	333
120/208V, 3-phase, 0.8 pf	100	347	80	278
120/240V, 3-phase, 0.8 pf	100	301	80	241
277/480V, 3-phase, 0.8 pf	100	150	80	120
600V, 3-phase, 0.8 pf	100	120	80	96
	NOTE: Consult your Generac dealer for additional voltages.			
<b>GENERATOR OUTPUT VOLTAGE/KVA-50Hz</b>				
110/220V, 1-phase, 1.0 pf	80	364	64	291
115/200V, 3-phase, 0.8 pf	100	289	80	231
100/200V, 3-phase, 0.8 pf	100	289	80	231
231/400V, 3-phase, 0.8 pf	100	144	80	115
480V, 3-phase, 0.8 pf	100	120	80	77
	NOTE: Consult your Generac dealer for additional voltage			
<b>MOTOR STARTING KVA</b>				
Maximum at 35% instantaneous voltage dip with standard alternator; 50/60 Hz	<u>120/208/240V</u>	<u>277/480V</u>	<u>120/208/240V</u>	<u>277/480V</u>
with optional alternator; 50/60 Hz	175/210	212/254	175/210	212/254
	234/281	276/331	234/281	276/331
<b>FUEL</b>				
Fuel consumption—60 Hz	<u>100%</u>	<u>80%</u>	<u>100%</u>	<u>80%</u>
Load gal./hr.	6.7	5.6	5.4	4.4
liters/hr.	25.4	21.0	20.3	16.8
Fuel consumption—50 Hz	<u>100%</u>	<u>80%</u>	<u>100%</u>	<u>80%</u>
gal./hr.	5.6	4.6	4.4	3.7
liters/hr.	21.0	17.5	16.8	14.0
Fuel pump lift	36"		36"	
<b>COOLING</b>				
Coolant capacity	System - lit. (US gal.)	15.9 (4.2)	15.9 (4.2)	
	Engine - lit. (US gal.)	6.4 (1.7)	6.4 (1.7)	
	Radiator - lit. (US gal.)	9.5 (2.5)	9.5 (2.5)	
Coolant flow/min.	60 Hz - lit. (US gal.)	128 (34)	128 (34)	
	50 Hz - lit. (US gal.)	107 (28)	107 (28)	
Heat rejection to coolant 60 Hz full load	BTU/hr.	269,500	215,600	
Heat rejection to coolant 50 Hz full load	BTU/hr.	224,500	179,600	
Inlet air	60 Hz - m <sup>3</sup> /min. (cfm)	204 (7200)	204 (7200)	
	50 Hz - m <sup>3</sup> /min. (cfm)	170 (6004)	170 (6004)	
Max. operating air temp to radiator *see note	°C (°F)	60 (140)	60 (140)	
Max. operating ambient temp *see note	°C (°F)	50 (122)	50 (122)	
<b>COMBUSTION AIR REQUIREMENTS</b>				
Flow at rated power	60 Hz - cfm	334	270	
	50 Hz - m <sup>3</sup> /min.	7.5	6.0	
<b>EXHAUST</b>				
Exhaust flow at rated output	60 Hz - m <sup>3</sup> /min. (cfm)	28.5 (1005)	22.8 (804)	
	50 Hz - m <sup>3</sup> /min. (cfm)	23 (812)	18 (636)	
Max recommended back pressure	"Hg	1.5	1.5	
Exhaust temperature 60 Hz (full load)	°C (°F)	638 (1180)	559 (1038)	
Exhaust outlet size		3.0"	3.0"	
<b>ENGINE</b>				
Rated RPM	60 / 50 Hz	1800 / 1500	1800 / 1500	
HP at rated KW	60 / 50 Hz	147 / 117	119 / 94	
Piston speed	60 Hz - m/min. (ft./min.)	414 (1358)	414 (1358)	
	50 Hz - m/min. (cfm)	345 (1132)	345 (1132)	
BMEP	60 / 50 Hz - psi	272 / 259	219 / 209	
<b>POWER ADJUSTMENTS FOR AMBIENT CONDITIONS</b>				
Temperature				
	-4.5% for every 10°C above - °C	40	40	
	-2.5% for every 10°F above - °F	104	104	
Altitude				
	-0.8% for every 100 m above - m	150	150	
	-2.5% for every 1000 ft. above - ft.	500	500	

\*Note: Values given are maximum temperatures to which power adjustments can be applied. Consult your Generac Power Systems representative if operating conditions exceed these maximums.

- High Coolant Temperature Automatic Shutdown
- Low Coolant Level Automatic Shutdown
- Low Oil Pressure Automatic Shutdown
- Overspeed Automatic Shutdown (Solid-state)
- Crank Limiter (Solid-state)
- Oil Drain Extension
- Radiator Drain Extension
- Factory-Installed Cool Flow Radiator
- Closed Coolant Recovery System
- UV/Ozone Resistant Hoses
- Rubber-Booted Engine Electrical Connections
- Secondary Fuel Filter
- Fuel Lockoff Solenoid
- Stainless Steel Flexible Exhaust Connection
- Battery Charge Alternator
- Battery Cables
- Battery Tray
- Vibration Isolation of Unit to Mounting Base
- 24 Volt, Solenoid-activated Starter Motor
- Air Cleaner
- Fan Guard
- Control Console
- Coolant Heater
- Radiator Duct Adapter

## OPTIONS

- **OPTIONAL COOLING SYSTEM ACCESSORIES**
  - 208/240V Coolant Heater
- **OPTIONAL FUEL ACCESSORIES**
  - Flexible Fuel Lines
  - UL Listed Fuel Tanks
  - Base Tank Low Fuel Alarm
  - Primary Fuel Filter
  - Primary Fuel Filter with Heater
- **OPTIONAL EXHAUST ACCESSORIES**
  - Critical Exhaust Silencer (Standard on enclosed genset)
- **OPTIONAL ELECTRICAL ACCESSORIES**
  - 2A Battery Charger
  - 10A Dual Rate Battery Charger
  - Battery, 12 Volt, 135 A.H.
- **OPTIONAL ALTERNATOR ACCESSORIES**
  - Alternator Upsizing
  - Alternator Strip Heater
  - Alternator Tropicalization
  - Voltage Changeover Switch
  - Main Line Circuit Breaker
- **CONTROL CONSOLE OPTIONS**
  - Digital Controller H100 (Bulletin 0172110SBY)
- **ADDITIONAL OPTIONAL EQUIPMENT**
  - Automatic Transfer Switch
  - Isochronous Governor
  - 21 Light Remote Annunciator
  - Remote Relay Panels
  - Unit Vibration Isolators (Pad/Spring)
  - Oil Make-Up System
  - Oil Heater
  - 5 Year Warranties
  - Export Boxing
  - GenLink® Communications Software
- **OPTIONAL ENCLOSURE**
  - Weather Protective
  - Sound Attenuated
  - Aluminum and Stainless Steel
  - Enclosed Muffler

**Distributed by:**

