

SG080 SG100

Liquid Cooled Gas Engine Generator Sets

Standby Power Rating

80KW 60 Hz / 80KVA 50 Hz
100KW 60 Hz / 100KVA 50 Hz

Prime Power Rating

65KW 60 Hz / 65KVA 50 Hz
80KW 60 Hz / 80KVA 50 Hz

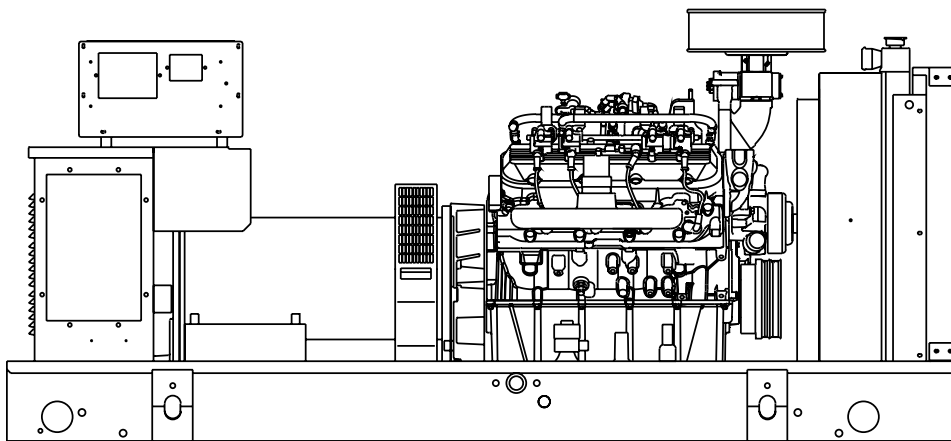

Power Matched

GENERAC 8.1GN ENGINE

Naturally Aspirated

FEATURES

- **INNOVATIVE DESIGN & PROTOTYPE TESTING** are key components of GENERAC'S success in "IMPROVING POWER BY DESIGN." But it doesn't stop there. Total commitment to component testing, reliability testing, environmental testing, destruction and life testing, plus testing to applicable CSA, NEMA, EGSA, and other standards, allows you to choose GENERAC POWER SYSTEMS with the confidence that these systems will provide superior performance.
- **TEST CRITERIA:**
 - ✓ PROTOTYPE TESTED
 - ✓ SYSTEM TORSIONAL TESTED
 - ✓ ELECTRO-MAGNETIC INTERFERENCE
 - ✓ NEMA MG1 EVALUATION
 - ✓ MOTOR STARTING ABILITY
 - ✓ SHORT CIRCUIT TESTING
 - ✓ UL 2200 COMPLIANCE AVAILABLE
- **SOLID-STATE, FREQUENCY COMPENSATED VOLTAGE REGULATION.** This state-of-the-art power maximizing regulation system is standard on all Generac models. It provides optimized FAST RESPONSE to changing load conditions and MAXIMUM MOTOR STARTING CAPABILITY by electronically torque-matching the surge loads to the engine.
- **SINGLE SOURCE SERVICE RESPONSE** from Generac's dealer network provides parts and service know-how for the entire unit, from the engine to the smallest electronic component. You are never on your own when you own a GENERAC POWER SYSTEM.
- **GENERAC TRANSFER SWITCHES, SWITCHGEAR AND ACCESSORIES.** Long life and reliability is synonymous with GENERAC POWER SYSTEMS. One reason for this confidence is that the GENERAC product line includes its own transfer systems, accessories, switchgear and controls for total system compatibility.

GENERAC®

POWER SYSTEMS, INC.

APPLICATION & ENGINEERING DATA

SG080/SG100

GENERATOR SPECIFICATIONS

TYPE	Four-pole, revolving field
ROTOR INSULATION	Class H
STATOR INSULATION	Class H
TOTAL HARMONIC DISTORTION	<3%
BALANCED TELEPHONE INFLUENCE FACTOR (TIF)	<50
ALTERNATOR	Self-ventilated and drip-proof
BEARINGS (PRE-LUBED & SEALED)	1
COUPLING	Direct, Flexible Disc
LOAD CAPACITY (STANDBY)	100%

NOTE: Emergency loading in compliance with NFPA 99, NFPA 110, paragraph 5-13.2.6. Generator rating and performance in accordance with ISO8528-5, BS5514, SAE J1349, ISO3046 and DIN6271 standards.

EXCITATION SYSTEM

- BRUSHLESS..... Magnetically coupled DC current ✓
 - Eight-pole exciter w/ battery-driven field boost ✓
 - Mounted outboard of main bearing ✓
- PERMANENT MAGNET EXCITER..... Eighteen pole exciter ✓
 - Magnetically coupled DC current ✓
 - Mounted outboard of main bearing ✓
- REGULATION..... Solid-state ✓
 - ±1% regulation ✓

GENERATOR FEATURES

- Four pole, revolving field generator, directly connected to the engine shaft through a heavy-duty, flexible disc for permanent alignment.
- Generator meets the temperature rise standards for class "F" insulation as defined by NEMA MG1-32.6, while the insulation system meets the requirements for the higher class "H" rating.
- All prototype models have passed a three-phase symmetrical short circuit test to assure system protection and reliability.
- All prototype models are tested for motor starting ability by measuring the instantaneous voltage dip with a waveform data acquisition system.
- All models utilize an advanced wire harness design for reliable interconnection within the circuitry.
- Magnetic circuit, including amortisseur windings, tooth and skewed stator design, provides a minimal level of waveform distortion and an electromagnetic interference level which meets accepted requirements for standard AM radio, TV, and marine radio telephone applications.
- Voltage waveform deviation, total harmonic content of the AC waveform, and T.I.F. (Telephone Influence Factor) have been evaluated to acceptable standards in accordance with NEMA MG1-32.
- Alternator is self-ventilated and drip-proof constructed.
- Fully life-tested protective systems, including "field circuit and thermal overload protection" and optional main-line circuit breakers capable of handling full output capacity.
- System Torsional acceptability confirmed during Prototype Testing.

ENGINE SPECIFICATIONS

MAKE	GENERAC
MODEL.....	8.1 GN
CYLINDERS.....	V-8
DISPLACEMENT.....	8.1 Liter (496 cu. in.)
BORE	108 mm (4.25 in.)
STROKE.....	111 mm (4.37 in.)
COMPRESSION RATIO	9.1:1
INTAKE AIR	Naturally Aspirated
NUMBER OF MAIN BEARINGS	5
CONNECTING RODS	Forged Steel
CYLINDER HEAD	Cast Iron
PISTONS.....	Coated Hypereutectic Cast Aluminum
CRANKSHAFT	High Density Nodular Iron

VALVE TRAIN

LIFTER TYPE	Hydraulic Roller
INTAKE VALVE MATERIAL.....	Heat Resistant Steel
EXHAUST VALVE MATERIAL	Stellite Faced
HARDENED VALVE SEATS	Standard

ENGINE GOVERNOR

- ELECTRONIC Standard || FREQUENCY REGULATION, NO-LOAD TO FULL LOAD | 0.5% |
| STEADY STATE REGULATION..... | ±0.25% |

LUBRICATION SYSTEM

TYPE OF OIL PUMP.....	Gear
OIL FILTER.....	Spin-on, Full flow, cartridge
CRANKCASE CAPACITY.....	8 quarts

COOLING SYSTEM

TYPE OF SYSTEM	Pressurized, closed recovery
WATER PUMP.....	Pre-lubed, self-sealing
TYPE OF FAN	Pusher
NUMBER OF FAN BLADES.....	6
DIAMETER OF FAN	560 mm (22 in.)
COOLANT HEATER.....	120V, 1800 W

FUEL SYSTEM

- FUEL
 - Natural Gas or L.P. Vapor Standard |
 - L.P. Liquid Withdrawal..... Optional |
- CARBURETOR..... Down draft |
- SECONDARY FUEL REGULATOR..... Nat. Gas or L.P. Vapor Systems |
- HOT WATER VAPORIZER..... L.P. Liquid Withdrawal Systems |
- AUTOMATIC FUEL LOCKOFF SOLENOID..... Standard |
- OPERATING FUEL PRESSURE VAPOR SYSTEMS 7" to 15" H₂O |

ELECTRICAL SYSTEM

BATTERY CHARGE ALTERNATOR.....	15 Amps at 12 V
STARTER MOTOR	12 V
RECOMMENDED BATTERY.....	(1) - 12 V, 700CCA, 27F
GROUND POLARITY.....	Negative

Rating definitions - Standby: Applicable for supplying emergency power for the duration of the utility power outage. No overload capability is available for this rating. (All ratings in accordance with BS5514, ISO3046 and DIN6271). Prime (Unlimited Running Time): Applicable for supplying electric power in lieu of commercially purchased power. Prime power is the maximum power available at variable load. A 10% overload capacity is available for 1 hour in 12 hours. (All ratings in accordance with BS5514, ISO3046, ISO8528 and DIN6271).

- High Coolant Temperature Automatic Shutdown
- Low Coolant Level Automatic Shutdown
- Low Oil Pressure Automatic Shutdown
- Overspeed Automatic Shutdown (Solid-state)
- Crank Limiter (Solid-state)
- Oil Drain Extension
- Radiator Drain Extension
- Factory-Installed Cool Flow Radiator
- Closed Coolant Recovery System
- UV/Ozone Resistant Hoses
- Rubber-Booted Engine Electrical Connections
- Fuel Lockoff Solenoid
- Secondary Fuel Regulator
- Stainless Steel Flexible Exhaust Connection
- Battery Charge Alternator
- Battery Cables
- Battery Tray
- Vibration Isolation of Unit to Mounting Base
- 12 Volt, Solenoid-Activated Starter Motor
- Air Cleaner
- Fan Guard
- Control Console
- Isochronous Governor
- Radiator Duct Adaptor

OPTIONS

■ OPTIONAL COOLING SYSTEM ACCESSORIES

- 208/240V Coolant Heater

■ OPTIONAL FUEL ACCESSORIES

- Flexible Fuel Lines

■ OPTIONAL EXHAUST ACCESSORIES

- Critical Exhaust Silencer

■ OPTIONAL ELECTRICAL ACCESSORIES

- Battery, 12 Volt, 135 A.H., 4DL
- Battery Heater
- 2A Battery Charger
- 10A Dual Rate Battery Charger
- Main Line Circuit Breaker

■ OPTIONAL ALTERNATOR ACCESSORIES

- Alternator Strip Heater
- Alternator Tropicalization
- Voltage Changeover Switch

■ CONTROL CONSOLE OPTIONS

- Analog control "C" Panel (Bulletin 0151160SBY)
- Analog/Digital control "E" Panel (Bulletin 0161310SBY)

■ ADDITIONAL OPTIONAL EQUIPMENT

- Automatic Transfer Switch
- 3 Light Remote Annunciator
- 5 Light Remote Annunciator

■ ADDITIONAL OPTIONAL EQUIPMENT (Cont)

- 20 Light Remote Annunciator
- Remote Relay Panel
- Unit Vibration Isolators
- Oil Make-Up System
- Oil Heater
- 5 Year Warranties
- Export Boxing
- GenLink® Communications Software

■ OPTIONAL ENCLOSURES

- Weather Protective
- Sound Attenuating
- Aluminum and Stainless Steel
- Enclosed Muffler

Distributed by:

Design and specifications subject to change without notice. Dimensions shown are approximate. Contact your Generac dealer for certified drawings. DO NOT USE THESE DIMENSIONS FOR INSTALLATION PURPOSES.

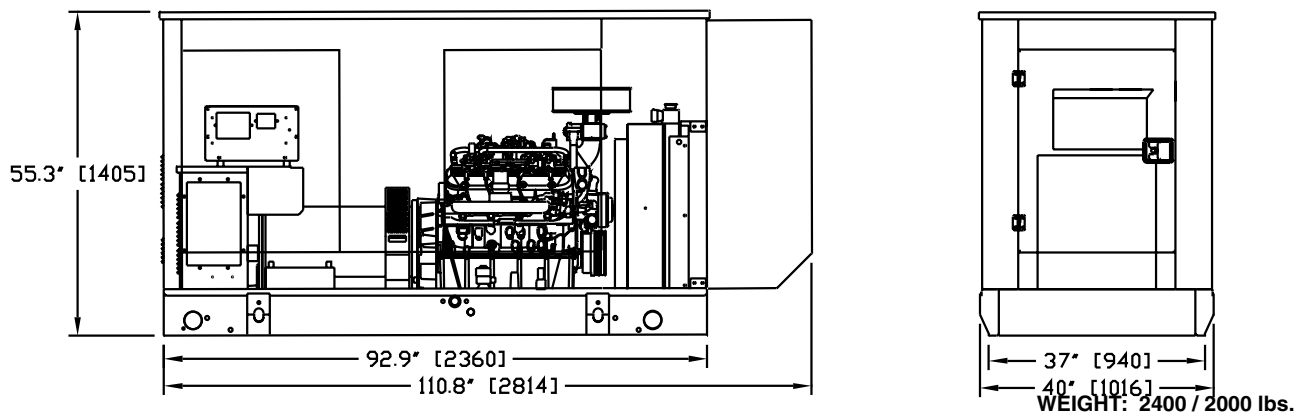

GENERAC® POWER SYSTEMS, INC. • P.O. BOX 8 • WAUKESHA, WI 53187

262/544-4811 • FAX 262/544-4851