

SD080

Liquid Cooled Diesel Engine Generator Sets

Standby Power Rating
80KW 60 Hz / 80KVA 50 Hz

Prime Power Rating
64KW 60 Hz / 64KVA 50 Hz

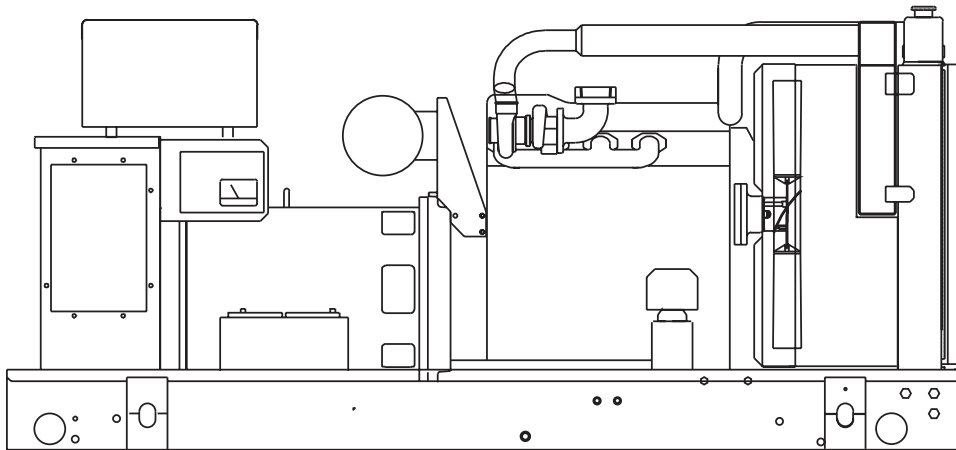

Power Matched
GENERAC 4.8DTA ENGINE
Naturally Aspirated

FEATURES

- **INNOVATIVE DESIGN & PROTOTYPE TESTING** are key components of GENERAC'S success in "IMPROVING POWER BY DESIGN." But it doesn't stop there. Total commitment to component testing, reliability testing, environmental testing, destruction and life testing, plus testing to applicable CSA, NEMA, EGSA, and other standards, allows you to choose GENERAC POWER SYSTEMS with the confidence that these systems will provide superior performance.
- **TEST CRITERIA:**
 - ✓ PROTOTYPE TESTED
 - ✓ SYSTEM TORSIONAL TESTED
 - ✓ ELECTRO-MAGNETIC INTERFERENCE
 - ✓ NEMA MG1 EVALUATION
 - ✓ MOTOR STARTING ABILITY
 - ✓ SHORT CIRCUIT TESTING
 - ✓ UL COMPLIANCE AVAILABLE
- **SOLID-STATE, FREQUENCY COMPENSATED VOLTAGE REGULATION.** This state-of-the-art power maximizing regulation system is standard on all Generac models. It provides optimized FAST RESPONSE to changing load conditions and MAXIMUM MOTOR STARTING CAPABILITY by electronically torque-matching the surge loads to the engine.
- **SINGLE SOURCE SERVICE RESPONSE** from Generac's dealer network provides parts and service know-how for the entire unit, from the engine to the smallest electronic component. You are never on your own when you own a GENERAC POWER SYSTEM.
- **ECONOMICAL DIESEL POWER.** Low cost operation due to modern diesel engine technology. Better fuel utilization plus lower cost per gallon provide real savings.
- **LONGER ENGINE LIFE.** Generac heavy-duty diesels provide long and reliable operating life.
- **GENERAC TRANSFER SWITCHES, SWITCHGEAR AND ACCESSORIES.** Long life and reliability is synonymous with GENERAC POWER SYSTEMS. One reason for this confidence is that the GENERAC product line includes its own transfer systems, accessories, switchgear and controls for total system compatibility.

GENERAC[®]
POWER SYSTEMS, INC.

GENERATOR SPECIFICATIONS

TYPE	Four-pole, revolving field
ROTOR INSULATION	Class H
STATOR INSULATION	Class H
TOTAL HARMONIC DISTORTION	<3%
TELEPHONE INTERFERENCE FACTOR (TIF)	<50
ALTERNATOR	Self-ventilated and drip-proof
BEARINGS (PRE-LUBED & SEALED)	1
COUPLING	Direct, Flexible Disc
LOAD CAPACITY (STANDBY)	100%
LOAD CAPACITY (PRIME)	110%

NOTE: Emergency loading in compliance with NFPA 99, NFPA 110, paragraph 5-13.2.6. Generator rating and performance in accordance with ISO8528-5, BS5514, SAE J1349, ISO3046 and DIN6271 standards.

EXCITATION SYSTEM

- BRUSHLESS Magnetically coupled DC current ✓
 - Eight-pole exciter w/ battery-driven field boost ✓
 - Mounted outboard of main bearing ✓
- PERMANENT MAGNET EXCITER Eighteen pole exciter ✓
 - Magnetically coupled DC current ✓
 - Mounted outboard of main bearing ✓
- REGULATION Solid-state ✓
 - ±1% regulation ✓

GENERATOR FEATURES

- Four pole, revolving field generator, directly connected to the engine shaft through a heavy-duty, flexible disc for permanent alignment.
- Generator meets the temperature rise standards for class "F" insulation as defined by NEMA MG1-32.6, while the insulation system meets the requirements for the higher class "H" rating.
- All prototype models have passed a three-phase symmetrical short circuit test to assure system protection and reliability.
- All prototype models are tested for motor starting ability by measuring the instantaneous voltage dip with a waveform data acquisition system.
- All models utilize an advanced wire harness design for reliable interconnection within the circuitry.
- Magnetic circuit, including amortisseur windings, tooth and skewed stator design, provides a minimal level of waveform distortion and an electromagnetic interference level which meets accepted requirements for standard AM radio, TV, and marine radio telephone applications.
- Voltage waveform deviation, total harmonic content of the AC waveform, and T.I.F. (Telephone Influence Factor) have been evaluated to acceptable standards in accordance with NEMA MG1-32.
- Alternator is self-ventilated and drip-proof constructed.
- Fully life-tested protective systems, including "field circuit and thermal overload protection" and optional main-line circuit breakers capable of handling full output capacity.
- System Torsional acceptability confirmed during Prototype Testing.

Rating definitions - Standby: Applicable for supplying emergency power for the duration of the utility power outage. No overload capability is available for this rating. (All ratings in accordance with BS5514, ISO3046 and DIN6271). Prime (Unlimited Running Time): Applicable for supplying electric power in lieu of commercially purchased power. Prime power is the maximum power available at variable load. A 10% overload capacity is available for 1 hour in 12 hours. (All ratings in accordance with BS5514, ISO3046, ISO8528 and DIN6271).

ENGINE SPECIFICATIONS

MAKE	GENERAC/DEUTZ
MODEL	BF4M1013FC
CYLINDERS	4
DISPLACEMENT	4.8 Liter (293 cu.in.)
BORE	108 mm (4.25 in.)
STROKE	130 mm (5.12 in.)
COMPRESSION RATIO	18.9:1
INTAKE AIR	Turbocharged/Aftercooled
NUMBER OF MAIN BEARINGS	5
CONNECTING RODS	4-Drop Forged Steel
CYLINDER HEAD	Cast Iron
PISTONS	4- Aluminum Alloy
CRANKSHAFT	Die Forged, Induction Hardened Steel

VALVE TRAIN

LIFTER TYPE	Solid
INTAKE VALVE MATERIAL	Heat Resistant Steel
EXHAUST VALVE MATERIAL	Heat Resistant Steel
HARDENED VALVE SEATS	Replaceable

ENGINE GOVERNOR

- ELECTRONIC Standard
- FREQUENCY REGULATION, NO-LOAD TO FULL LOAD ... 0.5%
- STEADY STATE REGULATION 0.25%

LUBRICATION SYSTEM

TYPE OF OIL PUMP	Gear
OIL FILTER	Full flow, Cartridge
CRANKCASE CAPACITY	11 Liters (11.7 qts.)

COOLING SYSTEM

TYPE OF SYSTEM	Pressurized, Closed Recovery
WATER PUMP	Pre-Lubed, Self-Sealing
TYPE OF FAN	Pusher
NUMBER OF FAN BLADES	6
DIAMETER OF FAN	560 mm (22 in.)
COOLANT HEATER	120V, 1800 W

FUEL SYSTEM

FUEL	#2D Fuel (Min Cetane #40)
	(Fuel should conform to ASTM Spec.)
FUEL FILTER	5 Micron
FUEL INJECTION PUMP	Bosch, Unit type cam driven
FUEL PUMP	Mechanical
INJECTORS	Multi-Hole, Nozzle Type
ENGINE TYPE	Direct Injection
FUEL LINE (Supply)	6.35 mm (0.25 in.)
FUEL RETURN LINE	6.35 mm (0.25 in.)

ELECTRICAL SYSTEM

BATTERY CHARGE ALTERNATOR	20 Amps at 12 V
STARTER MOTOR	12 V
RECOMMENDED BATTERY	12 Volt, 90 A.H., 27F
GROUND POLARITY	Negative

SD080

OPERATING DATA

	STANDBY				PRIME				
	SD080				SD080				
GENERATOR OUTPUT VOLTAGE/KW-60Hz	Rated AMP				Rated AMP				
120/240V, 1-phase, 1.0 pf	80			333	64			267	
120/208V, 3-phase, 0.8 pf	80			278	64			222	
120/240V, 3-phase, 0.8 pf	80			241	64			192	
277/480V, 3-phase, 0.8 pf	80			120	64			96	
600V, 3-phase, 0.8 pf	0			96	64			77	
	NOTE: Consult your Generac dealer for additional voltages.								
GENERATOR OUTPUT VOLTAGE/KVA-50Hz	Rated AMP				Rated AMP				
110/220V, 1-phase, 1.0 pf	64			291	51.2			233	
115/200V, 3-phase, 0.8 pf	80			231	64			185	
100/200V, 3-phase, 0.8 pf	80			231	64			185	
231/400V, 3-phase, 0.8 pf	80			115	64			92	
480V, 3-phase, 0.8 pf	80			96	64			77	
	NOTE: Consult your Generac dealer for additional voltage								
MOTOR STARTING KVA	480V				480V				
Maximum at 35% instantaneous voltage dip with standard alternator; 50/60 Hz	208/240/416V				208/240/416V				
with optional alternator; 50/60 Hz	134/164			158/193	134/164			158/193	
	230/281			271/331	230/281			271/331	
FUEL									
Fuel consumption—60 Hz	Load	25%	50%	75%	100%	25%	50%	75%	100%
	gal./hr.	1.8	3.2	4.5	5.9	1.4	2.6	3.6	4.7
	liters/hr.	6.7	12.3	17.2	22.3	5.4	9.8	13.8	17.9
Fuel consumption—50 Hz	gal./hr.	1.5	2.8	3.9	5.1	1.2	2.2	3.1	4.1
	liters/hr.	5.8	10.6	14.8	19.2	4.6	8.5	11.8	15.4
Fuel pump lift		40"				40"			
COOLING									
Coolant capacity	System - US gal. (lit.)	4.5 (17.0)				4.5 (17.0)			
	Engine - US gal. (lit.)	2.75 (10.4)				2.75 (10.4)			
Coolant flow/min.	60 Hz - US gal. (lit.)	19 (72)				19 (72)			
	50 Hz - US gal. (lit.)	16 (60)				16 (60)			
Heat rejection to coolant 60 Hz full load	BTU/hr.	229,688				189,493			
Heat rejection to coolant 50 Hz full load	BTU/hr.	191,330				157,848			
Inlet air	60 Hz - cfm (m ³ /min.)	7500 (212.4)				7500 (212.4)			
	50 Hz - cfm (m ³ /min.)	6225 (176.3)				6225 (176.3)			
Max. air temperature to radiator	°C (°F)	50 (122)				50 (122)			
Max. ambient temperature	°C (°F)	54 (130)				54 (130)			
COMBUSTION AIR REQUIREMENTS									
Flow at rated power	60 Hz - cfm (m ³ /min.)	295 (8.4)				236 (6.7)			
	50 Hz - cfm (m ³ /min.)	246 (7.0)				197 (5.6)			
EXHAUST									
Exhaust flow at rated output 60 Hz - cfm (m ³ /min.)	830 (23.5)				706 (20.0)				
	50 Hz - cfm (m ³ /min.)				588 (16.7)				
Max recommended back pressure	Hg	3.0				3.0			
Exhaust temperature 60 Hz (full load)	°F (°C)	1060 (571)				954 (512)			
Exhaust outlet size		2.5" O.D. Turbo				3.0" O.D. Muffler			
ENGINE									
Rated RPM	60 Hz / 50 Hz	1800 / 1500				1800 / 1500			
HP at rated KW	60 Hz / 50 Hz	125 / 104				100 / 83			
Piston speed	60 Hz - ft./min. (m/min.)	1536 (468)				1536 (468)			
	50 Hz - m/min.	390				390			
BMEP	60 Hz / 50 Hz - psi	189 / 187				151 / 150			
DERATION FACTORS									
Temperature									
	5% for every 10°C above - °C	25				25			
	2.77% for every 10°F above - °F	77				77			
Altitude									
	1.1% for every 100 m above - m	1524				1524			
	3.5% for every 1000 ft. above - ft.	5000				5000			

STANDARD ENGINE & SAFETY FEATURES

SD080

- High Coolant Temperature Automatic Shutdown
- Low Coolant Level Automatic Shutdown
- Low Oil Pressure Automatic Shutdown
- Overspeed Automatic Shutdown (Solid-state)
- Crank Limiter (Solid-state)
- Oil Drain Extension
- Radiator Drain Extension
- Factory-Installed Cool Flow Radiator
- Closed Coolant Recovery System
- UV/Ozone Resistant Hoses
- Rubber-Booted Engine Electrical Connections
- Coolant Heater
- Secondary Fuel Filter
- Fuel Lockoff Solenoid
- Stainless Steel Flexible Exhaust Connection
- Battery Charge Alternator
- Battery Cables
- Battery Tray
- Vibration Isolation of Unit to Mounting Base
- 12 Volt, Solenoid-activated Starter Motor
- Air Cleaner
- Fan Guard
- Control Console
- Air Duct Adaptor

OPTIONS

- **OPTIONAL COOLING SYSTEM ACCESSORIES**
 - 208/240V Coolant Heater
- **OPTIONAL FUEL ACCESSORIES**
 - Flexible Fuel Lines
 - UL Listed Fuel Tanks
 - Base Tank Low Fuel Alarm
 - Primary Fuel Filters
- **OPTIONAL EXHAUST ACCESSORIES**
 - Critical Exhaust Silencer
- **OPTIONAL ELECTRICAL ACCESSORIES**
 - 2A Battery Charger
 - 10A Dual Rate Battery Charger
 - Battery, 12 Volt, 135 A.H.
- **OPTIONAL ALTERNATOR ACCESSORIES**
 - Alternator Upsizing
 - Alternator Strip Heater
 - Alternator Tropicalization
 - Voltage Changeover Switch
 - Main Line Circuit Breaker
- **CONTROL CONSOLE OPTIONS**
 - Analog Control "C" Panel (Bulletin 0151160SBY)
 - Analog/Digital Control "E" Panel (Bulletin 0161310SBY)
 - Digital Control "D" Panel (Bulletin 0157210SBY)
- **ADDITIONAL OPTIONAL EQUIPMENT**
 - Automatic Transfer Switch
 - Isochronous Governor
 - 3 Light Remote Annunciator
 - 5 Light Remote Annunciator
 - 20 Light Remote Annunciator
 - Remote Relay Panels
 - Unit Vibration Isolators
 - Oil Make-Up System
 - Oil Heater
 - 5 Year Warranties
 - Export Boxing
 - GenLink® Communications Software
- **OPTIONAL ENCLOSURE**
 - Weather Protective
 - Sound Attenuated
 - Aluminum and Stainless Steel
 - Enclosed Muffler

Distributed by:

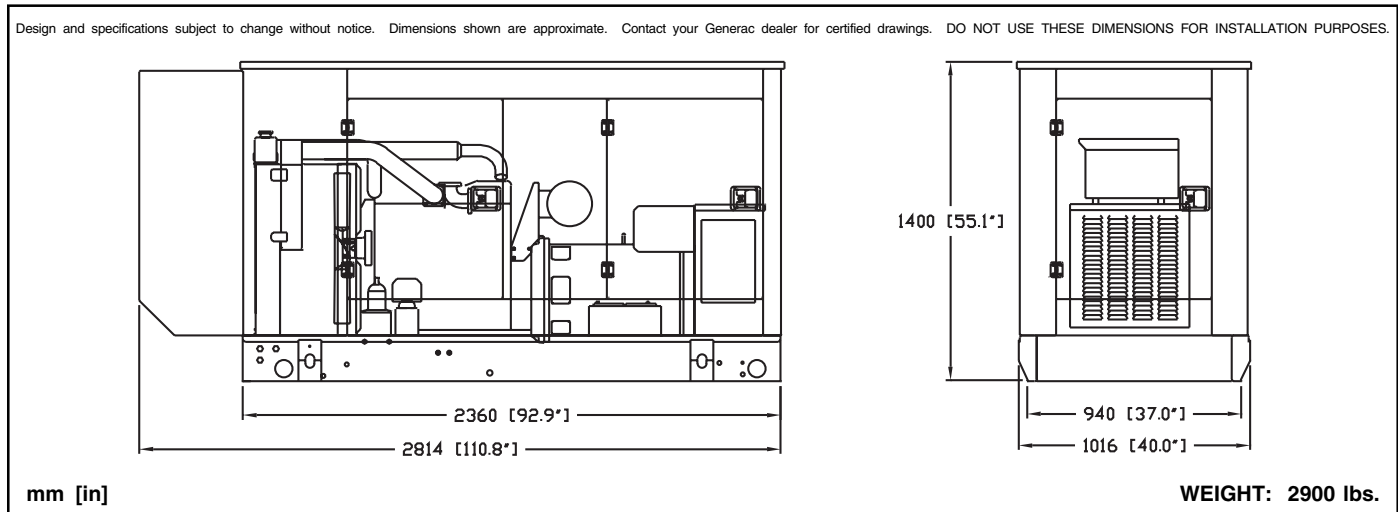

GENERAC POWER SYSTEMS, INC. • P.O. BOX 8 • WAUKESHA, WI 53187

262/544-4811 • FAX 262/544-4851