

SG125

Liquid Cooled Gas Engine Generator Sets

Standby Power Rating

125KW 60 Hz / 125KVA 50 Hz

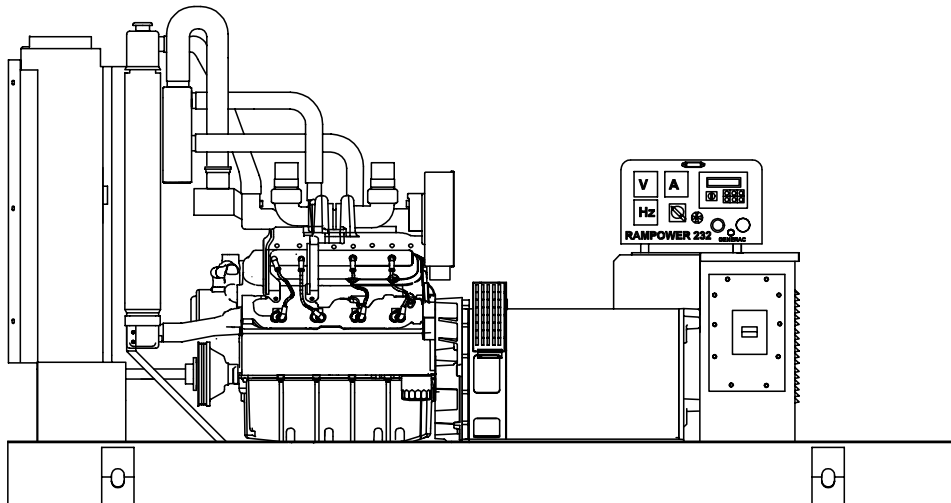

Power Matched

GENERAC 8.1TA ENGINE

Turbocharged / Aftercooled

FEATURES

- **INNOVATIVE DESIGN & PROTOTYPE TESTING** are key components of GENERAC'S success in "IMPROVING POWER BY DESIGN." But it doesn't stop there. Total commitment to component testing, reliability testing, environmental testing, destruction and life testing, plus testing to applicable CSA, NEMA, EGSA, and other standards, allows you to choose GENERAC POWER SYSTEMS with the confidence that these systems will provide superior performance.
- **TEST CRITERIA:**
 - ✓ PROTOTYPE TESTED
 - ✓ SYSTEM TORSIONAL TESTED
 - ✓ ELECTRO-MAGNETIC INTERFERENCE
 - ✓ NEMA MG1 EVALUATION
 - ✓ MOTOR STARTING ABILITY
 - ✓ SHORT CIRCUIT TESTING
 - ✓ UL 2200 COMPLIANCE AVAILABLE
- **SOLID-STATE, FREQUENCY COMPENSATED VOLTAGE REGULATION.** This state-of-the-art power maximizing regulation system is standard on all Generac models. It provides optimized FAST RESPONSE to changing load conditions and MAXIMUM MOTOR STARTING CAPABILITY by electronically torque-matching the surge loads to the engine.
- **SINGLE SOURCE SERVICE RESPONSE** from Generac's dealer network provides parts and service know-how for the entire unit, from the engine to the smallest electronic component. You are never on your own when you own a GENERAC POWER SYSTEM.
- **GENERAC TRANSFER SWITCHES, SWITCHGEAR AND ACCESSORIES.** Long life and reliability is synonymous with GENERAC POWER SYSTEMS. One reason for this confidence is that the GENERAC product line includes its own transfer systems, accessories, switchgear and controls for total system compatibility.

GENERAC[®]
POWER SYSTEMS, INC.

GENERATOR SPECIFICATIONS

TYPE	Four-pole, revolving field
ROTOR INSULATION	Class H
STATOR INSULATION	Class H
TOTAL HARMONIC DISTORTION	<3%
BALANCED TELEPHONE INFLUENCE FACTOR (TIF)	<50
ALTERNATOR	Self-ventilated and drip-proof
BEARINGS (PRE-LUBED & SEALED)	1
COUPLING	Direct, Flexible Disc
LOAD CAPACITY (STANDBY)	100%

NOTE: Emergency loading in compliance with NFPA 99, NFPA 110, paragraph 5-13.2.6. Generator rating and performance in accordance with ISO8528-5, BS5514, SAE J1349, ISO3046 and DIN6271 standards.

EXCITATION SYSTEMS

- BRUSHLESS..... Magnetically coupled DC current ✓
 - Eight-pole exciter w/ battery-driven field boost ✓
 - Mounted outboard of main bearing ✓
- PERMANENT MAGNET EXCITER..... Eighteen pole exciter ✓
 - (Optional) Magnetically coupled DC current ✓
 - Mounted outboard of main bearing ✓
- REGULATION..... Solid-state ✓
 - ±1% regulation ✓

GENERATOR FEATURES

- Four pole, revolving field generator, directly connected to the engine shaft through a heavy-duty, flexible disc for permanent alignment.
- Generator meets the temperature rise standards for class "F" insulation as defined by NEMA MG1-32.6, while the insulation system meets the requirements for the higher class "H" rating.
- All prototype models have passed a three-phase symmetrical short circuit test to assure system protection and reliability.
- All prototype models are tested for motor starting ability by measuring the instantaneous voltage dip with a waveform data acquisition system.
- All models utilize an advanced wire harness design for reliable interconnection within the circuitry.
- Magnetic circuit, including amortisseur windings, tooth and skewed stator design, provides a minimal level of waveform distortion and an electromagnetic interference level which meets accepted requirements for standard AM radio, TV, and marine radio telephone applications.
- Voltage waveform deviation, total harmonic content of the AC waveform, and T.I.F. (Telephone Influence Factor) have been evaluated to acceptable standards in accordance with NEMA MG1-32.
- Alternator is self-ventilated and drip-proof constructed.
- Fully life-tested protective systems, including "field circuit and thermal overload protection" and optional main-line circuit breakers capable of handling full output capacity.
- System Torsional acceptability confirmed during Prototype Testing.

ENGINE SPECIFICATIONS

MAKE	GENERAC
MODEL	8.1 GN
CYLINDERS	V-8
DISPLACEMENT	8.1 Liter (496 cu. in.)
BORE	108 mm (4.25 in.)
STROKE	111 mm (4.37 in.)
COMPRESSION RATIO	9.1:1
INTAKE AIR	Turbo / Aftercooled
NUMBER OF MAIN BEARINGS	5
CONNECTING RODS	Forged Steel
CYLINDER HEAD	Cast Iron
PISTONS	Coated Hypereutectic Cast Aluminum
CRANKSHAFT	High Density Nodular Iron

VALVE TRAIN

LIFTER TYPE	Hydraulic Roller
INTAKE VALVE MATERIAL	Heat Resistant Steel
EXHAUST VALVE MATERIAL	High Temperature Alloy
HARDENED VALVE SEATS	Standard

ENGINE GOVERNOR

- ELECTRONIC
 Standard |
- FREQUENCY REGULATION, NO-LOAD TO FULL LOAD
 0.5% |
- STEADY STATE REGULATION
 ±0.25% |

LUBRICATION SYSTEM

TYPE OF OIL PUMP	Gear
OIL FILTER	Spin-on, Full flow, cartridge
CRANKCASE CAPACITY	8 quarts

COOLING SYSTEM

TYPE OF SYSTEM	Pressurized, closed recovery
WATER PUMP	Pre-lubed, self-sealing
TYPE OF FAN	Puller
NUMBER OF FAN BLADES	7
DIAMETER OF FAN	26"
COOLANT HEATER	120V, 1800 W

FUEL SYSTEM

FUEL	Natural Gas Only	Standard
CARBURETOR	Down draft	
SECONDARY FUEL REGULATOR	Natural Gas	
SOLENOID	Standard	
OPERATING FUEL PRESSURE	7" to 15" H ₂ O	

ELECTRICAL SYSTEM

ENGINE BATTERY CHARGE ALTERNATOR	15 Amps at 12 V
STARTER MOTOR	12 V
RECOMMENDED BATTERY	(1) - 12 V, 700CCA, 27F
GROUND POLARITY	Negative

OPERATING DATA

		STANDBY			
		SG125			
GENERATOR OUTPUT VOLTAGE/KW-60 Hz		kW	Rated AMP		
120/240V, 1-phase, 1.0 pf	NOTE: Consult your Generac dealer for additional voltages.	125	521		
120/208V, 3-phase, 0.8 pf		125	434		
120/240V, 3-phase, 0.8 pf		125	376		
277/480V, 3-phase, 0.8 pf		125	188		
600V, 3-phase, 0.8 pf		125	150		
GENERATOR OUTPUT VOLTAGE/KVA-50Hz		kVA	Rated AMP		
110/220V, 1-phase, 1.0 pf	NOTE: Consult your Generac dealer for additional voltages.	100	455		
115/200V, 3-phase, 0.8 pf		125	361		
100/200V, 3-phase, 0.8 pf		125	361		
231/400V, 3-phase, 0.8 pf		125	180		
480V, 3-phase, 0.8 pf		125	150		
MOTOR STARTING KVA		231/240V		400/480V	
Maximum at 35% instantaneous voltage dip with standard alternator; 60 Hz		281		331	
with upsized alternator; 60 Hz		500		690	
FUEL					
Fuel consumption—60 Hz	Load	25%	50%	75%	100%
	ft ³ /hr.	449	898	1347	1796
Fuel consumption—50 Hz	ft ³ /hr.	373	745	1118	1491
COOLING					
Coolant capacity	System - lit. (US gal.)	37.1 (9.8)			
	Engine - lit. (US gal.)	7.6 (2.0)			
	Radiator - lit. (US gal.)	29.5 (7.8)			
Coolant flow/min.	60 Hz - lit. (US gal.)	234.1 (61.9)			
	50 Hz - lit. (US gal.)	195.1 (51.5)			
Heat rejection to coolant	BTU/hr.	526,000			
Inlet air	60 Hz - m ³ /min. (cfm)	261 (9,200)			
	50 Hz - m ³ /min. (cfm)	217 (7,667)			
Max. operating air temp. onto radiator*	°C (°F)	60 (140)			
Max. operating ambient temp.*	°C (°F)	50 (122)			
Max. external pressure drop on rad.	in. H ₂ O	0.5			
COMBUSTION AIR REQUIREMENTS					
Flow at rated power	60 Hz - m ³ /min. (cfm)	12.1 (378)			
	50 Hz - m ³ /min. (cfm)	9.5 (296)			
EXHAUST					
Exhaust flow at rated output					
	60 Hz - m ³ /min. (cfm)	35.3 (1247)			
	50 Hz - m ³ /min. (cfm)	27.6 (976.2)			
Max recommended back pressure	Kpa (Hg)	5.1 (1.5)			
Exhaust temperature at rated output	°C (°F)	710 (1311)			
Exhaust outlet size	mm (in.)	127 (5.0)			
ENGINE					
Rated RPM	60 Hz / 50 Hz	1800 / 1500			
HP at rated KW	60 Hz / 50 Hz	189 / 148			
Piston speed	60 Hz - m/min. (ft./min.)	6.7 (1311)			
	50 Hz - m/min. (ft./min.)	5.5 (1093)			
BMEP	60 Hz / 50 Hz - psi	168 / 158			
DERATION FACTORS					
Temperature					
	5% for every 10°C above - °C	25			
	2.77% for every 10°F above - °F	77			
Altitude					
	1.1% for every 100 m above - m	183			
	3.5% for every 1000 ft. above - ft.	600			

* Note: Values given are maximum temperatures to which power adjustments can be applied. Consult your Generac Power Systems representative if operating conditions exceed these maximums.

- High Coolant Temperature Automatic Shutdown
- Low Coolant Level Automatic Shutdown
- Low Oil Pressure Automatic Shutdown
- Overspeed Automatic Shutdown (Solid-state)
- Crank Limiter (Solid-state)
- Oil Drain Extension
- Radiator Drain Extension
- Factory-Installed Cool Flow Radiator
- Closed Coolant Recovery System
- UV/Ozone Resistant Hoses
- Rubber-Booted Engine Electrical Connections
- Fuel Lockoff Solenoid

- Secondary Fuel Regulator
- Stainless Steel Flexible Exhaust Connection
- Battery Charge Alternator
- Battery Cables
- Battery Tray
- Vibration Isolation of Unit to Mounting Base
- 12 Volt, Solenoid-Activated Starter Motor
- Air Cleaner
- Fan Guard
- Control Console
- Isochronous Governor
- Radiator Duct Adaptor

OPTIONS

■ OPTIONAL COOLING SYSTEM ACCESSORIES

- 208/240V Coolant Heater

■ OPTIONAL FUEL ACCESSORIES

- Flexible Fuel Lines

■ OPTIONAL EXHAUST ACCESSORIES

- Critical Exhaust Silencer

■ OPTIONAL ELECTRICAL ACCESSORIES

- Battery, 12 Volt, 135 A.H., 4DL
- Battery Heater
- 2A Battery Charger
- 10A Dual Rate Battery Charger
- Main Line Circuit Breaker

■ OPTIONAL ALTERNATOR ACCESSORIES

- Alternator Strip Heater
- Alternator Tropicalization
- Voltage Changeover Switch

■ CONTROL CONSOLE OPTIONS

- Analog control "C" Panel (Bulletin 0151160SBY)
- Analog/Digital control "E" Panel (Bulletin 0161310SBY)

■ ADDITIONAL OPTIONAL EQUIPMENT

- Automatic Transfer Switch
- 3 Light Remote Annunciator
- 5 Light Remote Annunciator

■ ADDITIONAL OPTIONAL EQUIPMENT (Cont)

- 20 Light Remote Annunciator
- Remote Relay Panel
- Unit Vibration Isolators
- Oil Make-Up System
- Oil Heater
- 5 Year Warranties
- Export Boxing
- GenLink® Communications Software

■ OPTIONAL ENCLOSURES

- Weather Protective
- Sound Attenuating
- Aluminum and Stainless Steel
- Enclosed Muffler

Distributed by:

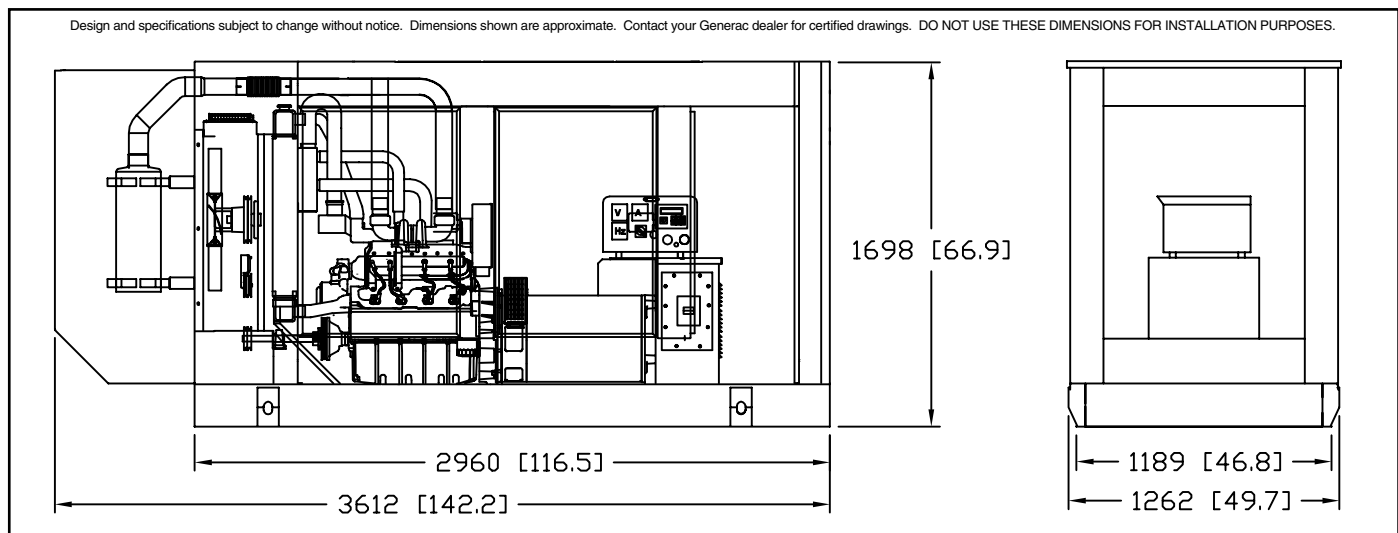

GENERAC® POWER SYSTEMS, INC. • P.O. BOX 8 • WAUKESHA, WI 53187

262/544-4811 • FAX 262/544-4851