

# SD375

## Liquid Cooled Diesel Engine Generator Sets

Standby Power Rating

375KW 60 Hz / 375KVA 50 Hz

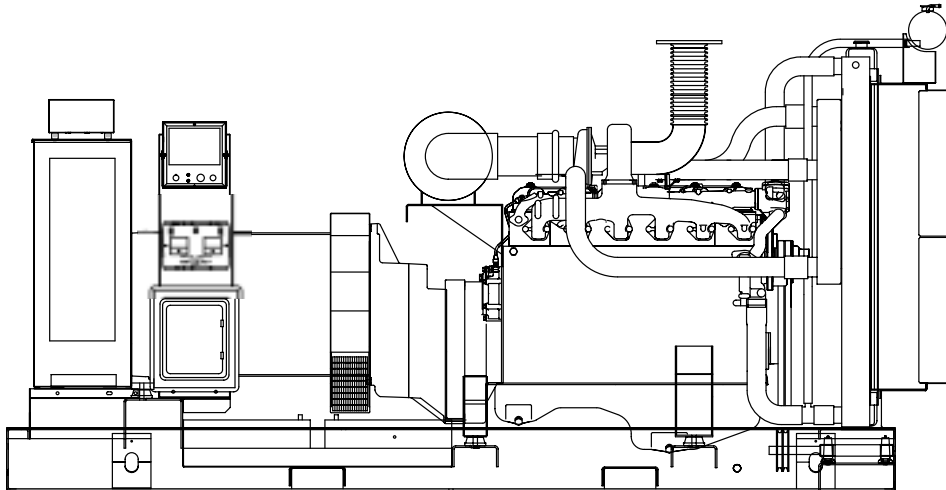

Power Matched  
**GENERAC 12.0DTA ENGINE**

Turbocharged, Aftercooled  
Gear Drive

## FEATURES

■ **INNOVATIVE DESIGN & PROTOTYPE TESTING** are key components of GENERAC'S success in "IMPROVING POWER BY DESIGN." But it doesn't stop there. Total commitment to component testing, reliability testing, environmental testing, destruction and life testing, plus testing to applicable CSA, NEMA, EGSA, and other standards, allows you to choose GENERAC POWER SYSTEMS with the confidence that these systems will provide superior performance.

■ **TEST CRITERIA:**

- ✓ PROTOTYPE TESTED
- ✓ SYSTEM TORSIONAL TESTED
- ✓ ELECTRO-MAGNETIC INTERFERENCE
- ✓ NEMA MG1 EVALUATION
- ✓ MOTOR STARTING ABILITY
- ✓ SHORT CIRCUIT TESTING
- ✓ UL 2200 COMPLIANCE AVAILABLE

■ **POWERMANAGER® DIGITAL CONTROL PLATFORM.** The PowerManager® Digital Control Platform (PM-DCP) is a powerful control system built around a 32 bit industrial microprocessor. Standard factory programming controls the entire engine generator system while allowing the PM-DCP, with its onboard PLC, to be

customized to meet any application requirement. The system is available on single unit gas, diesel or bi-fuel installations as well as Modular Paralleling Systems (MPS) from 200 kW - 3000 kW.

- **SINGLE SOURCE SERVICE RESPONSE** from Generac's dealer network provides parts and service know-how for the entire unit, from the engine to the smallest electronic component. You are never on your own when you own a GENERAC POWER SYSTEM.
- **ECONOMICAL POWER.** Low cost operation due to modern diesel engine technology. Better fuel utilization plus lower cost per gallon provide real savings
- **LONGER ENGINE LIFE.** Generac heavy-duty diesels provide long and reliable operating life.
- **GENERAC TRANSFER SWITCHES, SWITCHGEAR AND ACCESSORIES.** Long life and reliability is synonymous with GENERAC POWER SYSTEMS. One reason for this confidence is that the GENERAC product line includes its own transfer systems, accessories, switchgear and controls for total system compatibility.

# GENERAC®

---

## POWER SYSTEMS, INC.

## GENERATOR SPECIFICATIONS

TYPE .....	Four-pole, revolving field
ROTOR INSULATION .....	Class H
STATOR INSULATION .....	Class H
TOTAL HARMONIC DISTORTION .....	<3%
TELEPHONE INTERFERENCE FACTOR (TIF) .....	<50
ALTERNATOR .....	Self-ventilated and drip-proof
BEARINGS (PRE-LUBED & SEALED) .....	1
COUPLING .....	Direct, Flexible Disc
LOAD CAPACITY (STANDBY) .....	100%

**NOTE: Emergency loading in compliance with NFPA 99, NFPA 110, paragraph 5-13.2.6. Generator rating and performance in accordance with ISO8528-5, BS5514, SAE J1349, ISO3046 and DIN6271 standards.**

### EXCITATION SYSTEM

PERMANENT MAGNET EXCITER .....	Eighteen-pole exciter ✓
	Magnetically coupled DC current ✓
	Mounted outboard of main bearing ✓
REGULATION .....	Solid-state ✓
	±1% regulation ✓

## GENERATOR FEATURES

- Four pole, revolving field generator, connected to the engine shaft through a heavy-duty gear reduction unit for permanent alignment.
- Generator meets the temperature rise standards for class "F" insulation as defined by NEMA MG1-32.6, while the insulation system meets the requirements for the higher class "H" rating.
- All prototype models have passed a three-phase symmetrical short circuit test to assure system protection and reliability.
- All prototype models are tested for motor starting ability by measuring the instantaneous voltage dip with a waveform data acquisition system.
- All models utilize an advanced wire harness design for reliable interconnection within the circuitry.
- Magnetic circuit, including amortisseur windings, tooth and skewed stator design, provides a minimal level of waveform distortion and an electromagnetic interference level which meets accepted requirements for standard AM radio, TV, and marine radio telephone applications.
- Voltage waveform deviation, total harmonic content of the AC waveform, and T.I.F. (Telephone Influence Factor) have been evaluated to acceptable standards in accordance with NEMA MG1-32.
- Alternator is self-ventilated and drip-proof constructed.
- Fully life-tested protective systems, including "field circuit and thermal overload protection" and optional main-line circuit breakers capable of handling full output capacity.
- System Torsional acceptability confirmed during Prototype Testing.

## ENGINE SPECIFICATIONS

MAKE .....	GENERAC
MODEL .....	12.0DTA
CYLINDERS .....	6 in-line
DISPLACEMENT .....	11.945 Liter (729 cu. in.)
BORE .....	130 mm (5.11 in.)
STROKE .....	150 mm (5.91 in.)
COMPRESSION RATIO .....	15.5:1
INTAKE AIR .....	Turbocharged, Aftercooled
NUMBER OF MAIN BEARINGS .....	7
CONNECTING RODS .....	6-Carbon Steel
CYLINDER HEAD .....	(6) 1-Cylinder Cast Iron with Overhead Valve
PISTONS .....	6-Heat Resistant Aluminum Alloy
CRANKSHAFT .....	Case Hardened, Die Forged, Carbon Steel

### VALVE TRAIN

LIFTER TYPE .....	Solid
INTAKE VALVE MATERIAL .....	Special Heat Resistant Steel
EXHAUST VALVE MATERIAL .....	Sellited Faced Heat Resistant Steel
HARDENED VALVE SEATS .....	Replaceable

### ENGINE GOVERNOR

<input type="checkbox"/> ELECTRONIC .....	Standard
FREQUENCY REGULATION, NO-LOAD TO FULL LOAD ...	0.5%
STEADY STATE REGULATION .....	±0.25%

### LUBRICATION SYSTEM

TYPE OF OIL PUMP .....	Gear
OIL FILTER .....	Bypass and Full flow, cartridge
CRANKCASE CAPACITY .....	31 Liters (8.2 U.S. gal.)

### COOLING SYSTEM

TYPE OF SYSTEM .....	Pressurized, closed recovery
WATER PUMP .....	Pre-lubed, self-sealing
TYPE OF FAN .....	Puller
NUMBER OF FAN BLADES .....	8
DIAMETER OF FAN .....	991 mm (39 in.)
COOLANT HEATER .....	240V, 2000 W

### FUEL SYSTEM

FUEL .....	#2D Fuel (Min Cetane #40) (Fuel should conform to ASTM Spec.)
FUEL FILTER .....	10 Micron
FUEL INJECTION PUMP .....	Bosch PE6P Type
FUEL PUMP .....	Mechanical
INJECTORS .....	Multi-hole, nozzle type
ENGINE TYPE .....	Direct injection
FUEL LINE (Supply) .....	9.53 mm (0.375 in.)
FUEL RETURN LINE .....	9.53 mm (0.375 in.)

### ELECTRICAL SYSTEM

BATTERY CHARGE ALTERNATOR .....	35 Amps at 24 V
STARTER MOTOR .....	24 V
RECOMMENDED BATTERY .....	(2)—12V, 135 AH
GROUND POLARITY .....	Negative

SD375

**OPERATING DATA**

		<b>STANDBY</b>			
		<b>SD375</b>			
<b>GENERATOR OUTPUT VOLTAGE/KW-60Hz</b>		<b>kW</b>		<b>Rated AMP</b>	
277/480V, 3-phase, 0.8 pf	NOTE: Consult your Generac dealer for additional voltages.	375		564	
600V, 3-phase, 0.8 pf		375		451	
<b>GENERATOR OUTPUT VOLTAGE/KVA-50Hz</b>		<b>kW</b>		<b>Rated AMP</b>	
231/400V, 3-phase, 0.8 pf	NOTE: Consult your Generac dealer for additional voltages.	375		541	
480V, 3-phase, 0.8 pf		375		451	
<b>MOTOR STARTING KVA</b>		<b>208/240V</b>		<b>480V</b>	
Maximum at 35% instantaneous voltage dip with standard alternator; 60 Hz		975		1410	
<b>FUEL</b>					
Fuel consumption—60 Hz	Load	<b>25%</b>	<b>50%</b>	<b>75%</b>	<b>100%</b>
	liters/hr.	34.0	64.4	92.3	119.2
	gal./hr.	9.0	17.0	24.4	31.5
Fuel consumption—50 Hz	liters/hr.	27.2	51.5	73.8	95.4
	gal./hr.	7.2	13.6	19.5	25.2
<b>COOLING</b>					
Coolant capacity	System - lit. (US gal.)	78.5 (20.8)			
	Engine - lit. (US gal.)	22.0 (5.8)			
	Radiator - lit. (US gal.)	56.6 (15.0)			
Coolant flow/min.	60 Hz - lit. (US gal.)	683.3 (180.5)			
	50 Hz - lit. (US gal.)	569.4 (150.4)			
Heat rejection to coolant - full load	BTU/hr.	1,265,000			
Radiator air flow	60 Hz - m <sup>3</sup> /min. (cfm)	991 (35,000)			
	50 Hz - m <sup>3</sup> /min. (cfm)	826 (29,167)			
Max. external pressure drop after radiator	in. H <sub>2</sub> O	0.5			
Max. operating air temp. onto radiator	C (°F)	60 (140) *see note			
Max. operating ambient temp.	C (°F)	50 (122) *see note			
<b>COMBUSTION AIR REQUIREMENTS</b>					
Flow at rated power	60 Hz - m <sup>3</sup> /min. (cfm)	35.6 (1257)			
	50 Hz - m <sup>3</sup> /min. (cfm)	28.0 (990)			
<b>EXHAUST</b>					
Exhaust flow at rated output	60 Hz - m <sup>3</sup> /min. (cfm)	120.0 (4237)			
	50 Hz - m <sup>3</sup> /min. (cfm)	94.5 (3337)			
Max recommended back pressure	kPa ("Hg)	5.1 (1.5)			
Exhaust temperature at rated output	°C (°F)	732 (1350)			
Exhaust outlet size		5" ANSI Flange			
<b>ENGINE</b>					
Rated RPM	60 Hz / 50 Hz	2280 / 1900			
HP at rated kW <sub>e</sub> (gross)	60 Hz / 50 Hz	555 / 437			
Piston speed	60 Hz - m/min. (ft./min.)	685 (2249)			
	50 Hz - m/min. (ft./min.)	571 (1874)			
BMEP	60 Hz / 50 Hz - psi	264 / 249			
<b>POWER ADJUSTMENT FOR AMBIENT CONDITIONS</b>					
Temperature	-4.5% for every 10°C above - °C	25			
	-2.5% for every 10°F above - °F	77			
Altitude	-0.8% for every 100 m above - m	1066			
	-2.5% for every 1000 ft. above - ft.	3500			

\*Note: Values given are maximum temperatures to which power rating adjustments apply. Consult your Generac representative if operating conditions exceed these maximums.

- High Coolant Temperature Automatic Shutdown
- Low Coolant Level Automatic Shutdown
- Low Oil Pressure Automatic Shutdown
- Overspeed Automatic Shutdown (Solid-state)
- Crank Limiter (Solid-state)
- Oil Drain Extension
- Radiator Drain Extension
- Factory-Installed Cool Flow Radiator
- Closed Coolant Recovery System
- UV/Ozone Resistant Hoses
- Rubber-Booted Engine Electrical Connections
- Primary Fuel Filter
- Fuel Lockoff Solenoid
- Stainless Steel Flexible Exhaust Connection
- Battery Charge Alternator
- Battery Cables
- Battery Tray
- Vibration Isolation of Unit to Mounting Base
- 24 Volt, Solenoid-activated Starter Motor
- Air Cleaner
- Fan Guard
- Control Console
- Coolant Heater, 240V
- Isochronous Governor
- Radiator Duct Adapter

## POWERMANAGER® DIGITAL CONTROL PLATFORM

The PowerManager® Generator Controller (PM-GC) is a fully programmable, integrated digital generator control console, using a 32-bit industrial microprocessor to handle all the control, monitoring, input and output genset functions. The open architecture used allows customizing the control to meet any customer requirement, yet maintaining the simplicity of operating 'as is' with the factory default programming. (see Generac bulletin #0168840SBY)

## OPTIONS

### OPTIONAL COOLING SYSTEM ACCESSORIES

- Coolant Heater, 120V

### OPTIONAL FUEL ACCESSORIES

- Flexible Fuel Lines
- UL Listed Base Tank
- Base Tank Low Fuel Alarm
- Secondary Fuel Filters and Heaters

### OPTIONAL EXHAUST ACCESSORIES

- Critical Exhaust Silencer (Std. on enclosed gensets)

### OPTIONAL ELECTRICAL ACCESSORIES

- Battery, 12 Volt, 135 A.H., 4D (2 req'd)
- Battery, 12 Volt, 225 A.H., 8D (2 req'd)
- 2A Battery Charger
- 10A Dual Rate Battery Charger
- Battery Heater

### OPTIONAL ALTERNATOR ACCESSORIES

- Alternator Upsizing
- Alternator Strip Heater
- Alternator Tropicalization
- Main Line Circuit Breaker
- Analog Meter Package

### ADDITIONAL OPTIONAL EQUIPMENT

- Automatic Transfer Switch
- 5 Light Remote Annunciator
- 20 Light Remote Annunciator
- Remote Relay Panel
- Unit Vibration Isolators
- Oil Make-Up System
- Oil Heater
- 5 Year Warranties
- Export Boxing
- GenLink® Communications Software
- SCAQMD Certification

### OPTIONAL ENCLOSURES

- Weather Protective with Enclosed Muffler
- Sound Attenuated with Enclosed Muffler
- Aluminum and Stainless Steel

Distributed by:

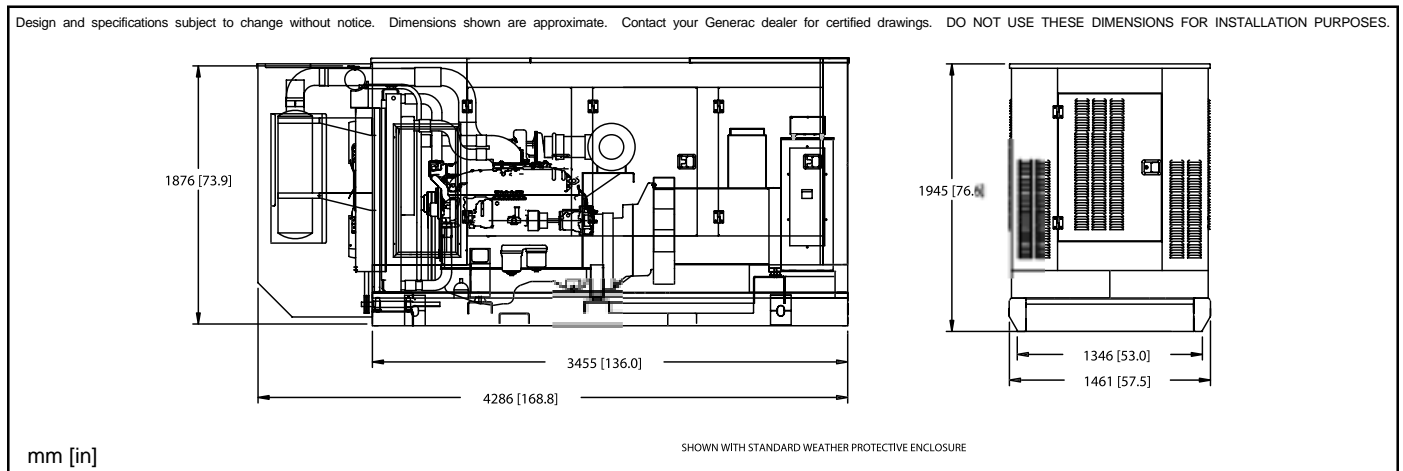

GENERAC® POWER SYSTEMS, INC. • P.O. BOX 8 • WAUKESHA, WI 53187

262/544-4811 • FAX 262/544-4851