

# MD400

## For Generac Modular Power System (MPS)

Standby Power Rating  
400KW 60 Hz

Prime Power Rating <sup>(1)</sup>  
300KW 60 Hz

Power Matched

**GENERAC 16.0DTA ENGINE**  
Turbocharged / Aftercooled

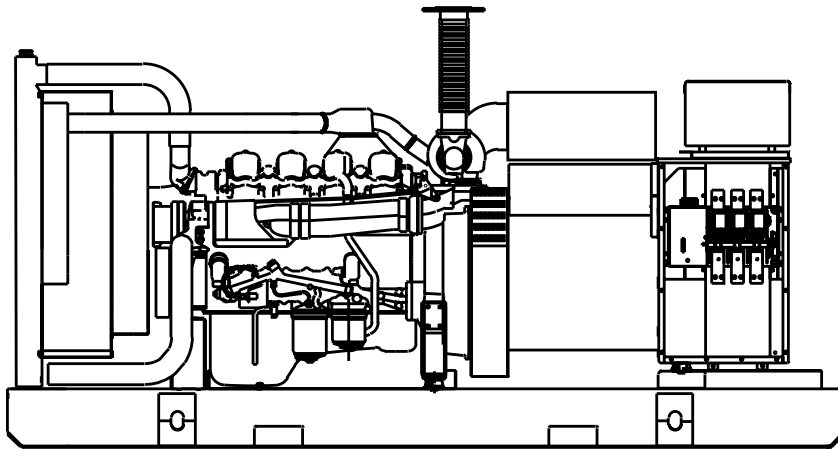

### PowerManager® Digital Control Platform

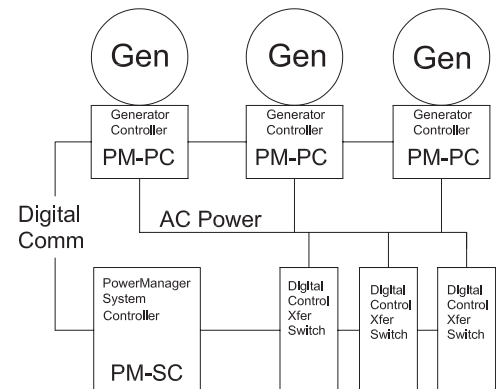

## FEATURES

(1) Prime power unit not available at this time.

- **INNOVATIVE DESIGN & PROTOTYPE TESTING** are key components of GENERAC'S success in "IMPROVING POWER BY DESIGN." But it doesn't stop there. Total commitment to component testing, reliability testing, environmental testing, destruction and life testing, plus testing to applicable CSA, NEMA, EGSA, and other standards, allows you to choose GENERAC POWER SYSTEMS with the confidence that these systems will provide superior performance.
- **PARALLELING SYSTEM FEATURES:**
  - ✓ AUTO SYNCHRONIZATION
  - ✓ ISOCHRONOUS LOAD SHARING
  - ✓ REVERSE POWER PROTECTION
  - ✓ MAXIMUM POWER PROTECTION
  - ✓ ELECTRICALLY OPERATED MECHANICALLY HELD TRANSFER SYSTEM
  - ✓ REDUNDANT OPERATION AND INCREASED RELIABILITY
  - ✓ UL2200 LISTED
- **POWERMANAGER® DIGITAL CONTROL PLATFORM.** The PowerManager Digital Control Platform (PM-DCP) is a powerful control system built around a 32-bit, industrial microprocessor. Standard factory programming controls the entire engine/generator

system, while allowing the PM-DCP, with its onboard PLC, to be customized to meet any application requirement. The system is available on single unit gas, diesel or bi-fuel installations as well as Modular Paralleling Systems (MPS) from 350 kW - 3000 kW.

- **SINGLE SOURCE SERVICE RESPONSE** from Generac's dealer network provides parts and service know-how for the entire unit, from the engine to the smallest electronic component. You are never on your own when you own a GENERAC POWER SYSTEM.
- **ECONOMICAL DIESEL POWER.** Low cost operation due to modern diesel engine technology. Better fuel utilization plus lower cost per gallon provide real savings.
- **LONGER ENGINE LIFE.** Generac heavy-duty diesels provide long and reliable operating life.
- **GENERAC TRANSFER SWITCHES, POWERMANAGER® AND ACCESSORIES.** Long life and reliability is synonymous with GENERAC POWER SYSTEMS. One reason for this confidence is that the GENERAC product line includes its own transfer systems, accessories, and PowerManager® controls for total system compatibility.

# GENERAC®

# APPLICATION & ENGINEERING DATA

MD400 MPS

## GENERATOR SPECIFICATIONS

TYPE .....	Generac 520 mm PMG
130°C Rating STD .....	400kW
SHORT CIRCUIT RATIO .....	0.770
SYNCHRONOUS REACTANCE .....	3.050 pu
NEGATIVE SEQUENCE REACTANCE .....	0.234 pu
ZERO SEQUENCE REACTANCE .....	0.056 pu
TRANSIENT REACTANCE .....	0.176 pu
SUBTRANSIENT REACTANCE .....	0.148 pu
OVERSPEED .....	2250 RPM
PHASE SEQUENCE .....	ABC
VOLTAGE BALANCE .....	0.2%
THD .....	5%
TIF .....	<50
VOLTAGE DIP FULL LOAD APPLICATION .....	12.5%
VOLTAGE OVERSHOOT LOAD REJECT .....	15%
MOTOR STARTING CHARACTERISTICS .....	(See Chart pg. 3)
GENERATOR EFFICIENCY	
• 94.8% @ 1.0 pf Full Load 480 volt	
• 90% @ 0.8 pf Full Load 480 volt	
BEARINGS (PRELUBED AND SEALED) .....	1
COUPLING .....	Direct Flex Disk
LOAD CAPACITY (STANDBY) .....	100%
LOAD CAPACITY (PRIME) .....	110%

## CONTROL SYSTEM PM-PC (See Note 4)

The Generac PowerManager™ Generator Control is mounted at the generator set and monitors all engine and alternator parameters:

- High/Low Battery
- High Oil Temp
- Low Oil Pressure
- Low Coolant Level
- High Coolant Level
- Low Coolant Level
- Overspeed/Underspeed
- Sensor Failures
- High/Low Frequency
- Pre-alarm Hi Oil Temp
- Pre-alarm Lo Oil Pressure
- Overcrank
- Pre-alarm Hi Coolant
- Critical Low Fuel
- Over/Under Voltage
- High/Lo Fuel

The instrumentation screen displays the following:

- AC volts
- Frequency
- Power Factor
- Coolant level
- Fuel level(%)
- Oil Pressure
- AC amps
- kW
- Coolant Temp
- Run-time Hours
- Battery Voltage
- Engine Speed

■ Serial communication to the PowerManager System Controller via RS485 connection

■ Programmable

■ Built in synchronizer for paralleling control and protection

■ Digital Voltage Regulator for precise control

■ Three pole 1000 amp paralleling switch

- Rated 600 volts
- UL recognized device
- Electrically operated – Mechanically held
- Built in ARC suppression

■ Mainline circuit breaker 700 amp 3 pole mounted in series with paralleling switch

■ Generator Connection Box mounted on right side (facing rear) 12" x 22" x 36" access from side, top, bottom to paralleling switch

## ENGINE SPECIFICATIONS

MAKE .....	GENERAC
MODEL .....	1600TA
CYLINDERS .....	V-8
DISPLACEMENT - liter/(cu. in.) .....	16.0 (976)
BORE - mm/(in.) .....	135 (5.31)
STROKE - mm/(in.) .....	140 (5.51)
COMPRESSION RATIO .....	15.5:1
INTAKE AIR .....	Turbocharged/Aftercooled (Air to Air)
NUMBER OF MAIN BEARINGS .....	5
CONNECTING RODS .....	I-Beam Section
CYLINDER HEAD .....	Individual Cylinder Heads/Two Valves
PISTONS .....	Open Chamber/Oil Cooled
CRANKSHAFT .....	Counter Weighted Type

### VALVE TRAIN

LIFTER TYPE .....	Solid
HARDENED VALVE SEATS .....	Yes

### ENGINE GOVERNOR

<input type="checkbox"/> ELECTRONIC / ISOCHRONOUS .....	Barber Colman / Generac
STEADY STATE FREQUENCY REGULATION .....	±0.25%

### LUBRICATION SYSTEM

TYPE OF OIL PUMP .....	Gear
OIL FILTER .....	Full Flow Cartridge and Bypass
CRANKCASE CAPACITY - liter/(gal.) .....	34.8 (9.2)

### COOLING SYSTEM

TYPE OF SYSTEM .....	Pressurized, Closed Recovery
WATER PUMP .....	Centrifugal Type, Belt Driven
TYPE OF FAN .....	Pusher
NUMBER OF FAN BLADES .....	7
DIAMETER OF FAN - mm/(in.) .....	990 (39.0)
COOLANT HEATER .....	240V(2000W)

### FUEL SYSTEM

FUEL .....	No. 2 Diesel Fuel (Fuel should conform to ASTM Spec.)
FUEL FILTER .....	Full Flow Cartridge
FUEL INJECTION PUMP .....	Bosch P Type x 1
FUEL PUMP .....	Bosch/Piston Type
INJECTORS .....	Bosch Multi-Hole
FUEL LINE (Supply) .....	1/2"FNPT
FUEL RETURN LINE .....	1/2"FNPT

### ELECTRICAL SYSTEM

BATTERY CHARGE ALTERNATOR (ENGINE DRIVEN) ...	30 Amps at 24V
STARTER MOTOR .....	6.0 kW at 24V
RECOMMENDED BATTERY .....	2 x 12V 700 CCA 27F
GROUND POLARITY .....	Negative

Rating definitions - Standby: Applicable for supplying emergency power for the duration of the utility power outage. No overload capability is available for this rating. (All ratings in accordance with BS5514, ISO3046 and DIN6271). Prime (Unlimited Running Time): Applicable for supplying electric power in lieu of commercially purchased power. Prime power is the maximum power available at variable load. A 10% overload capacity is available for 1 hour in 12 hours. (All ratings in accordance with BS5514, ISO3046, ISO8528 and DIN6271). Prime power is not available at this time for MPS units.

## MD400 MPS

### OPERATING DATA

		<b>STANDBY</b>			
		<b>MD400</b>			
<b>GENERATOR OUTPUT VOLTAGE/KW—60Hz</b>		<b>KW</b>	<b>Rated AMP</b>		
277/480V, 3-phase, 0.8 pf	NOTE: Consult your Generac dealer for additional voltages.	400	601		
600V, 3-phase, 0.8 pf		400	481		
<b>MOTOR STARTING KVA</b>					
Locked rotor kVA at 35% instantaneous voltage dip with standard alternator; 60 Hz-kVA		<b>480V</b>			
* see note 1		1342			
<b>FUEL</b>					
Fuel consumption—60 Hz	Load gal./hr.	<b>100 kW</b>	<b>200 kW</b>	<b>300 kW</b>	<b>400 kW</b>
* see note 3		8.3	14.3	21.3	29.0
Fuel pump lift	in.	48			
<b>COOLING</b>					
Coolant capacity	System - lit./gal.	89 (23.5)			
	Engine - lit./gal.	30 (7.9)			
	Radiator - lit./gal.	55 (14.5)			
Coolant flow/min.	60 Hz - lit./gal.	674 (178)			
Heat rejection to coolant	60 Hz - BTU/hr.	1,070,000			
Radiator air flow	60 Hz - m <sup>3</sup> /min. (cfm)	680 (24,000)			
Max. operating air temp to radiator	°C (°F)	60 (140) * see note #5			
Max. operating ambient temp	°C (°F)	50 (122) * see note #5			
Max. external pressure drop after radiator	in. H <sub>2</sub> O	1.0			
<b>COMBUSTION AIR REQUIREMENTS</b>					
Flow at rated power	60 Hz - m <sup>3</sup> /min. (cfm)	38.4 (1356)			
<b>EXHAUST</b>					
Exhaust flow at rated output	60 Hz - m <sup>3</sup> /min. (cfm)	126 (4443)			
Maximum recommended back pressure	kPa (" Hg)	5.1 (1.5)			
Exhaust temperature at rated output	°C (°F)	704 (1300)			
Exhaust outlet size	inches	2 - 5" ANSI Flange			
<b>ENGINE</b>					
Rated RPM	60 Hz	1800			
HP at rated kW <sub>e</sub> (gross)	60 Hz	598			
Piston speed	60 Hz - m/sec. (ft./min)	8.4 (1653)			
BMEP	60 Hz - psi	270			
<b>POWER ADJUSTMENTS FOR AMBIENT CONDITIONS</b>					
Temperature	-4.5% for every 10°C above - °C	40			
	-2.5% for every 10°F above - °F	104			
Altitude	-0.8% for every 100 m above - m	1067			
	-2.5% for every 1000 ft. above - ft.	3500			

#### Notes:

- Motor starting kVA adds directly for each generator on the bus. With Generac's PowerManager® Digital Control Platform, the load is shared proportionally.
- Maximum distance between generator sets is determined by the voltage drop of the power conductors and the maximum distance allowed for the RS485 connection. If the distance between units exceeds 500 feet, consult your Generac representative for wire and communication recommendations.
- Fuel consumption like motor starting kVA is additive. Each generator will proportionally share the load and the fuel consumption will be based on the percentage of load shared.
- A complete MPS system requires a PowerManager Paralleling Controller (PM-PC), a PowerManager System Controller (PM-SC), and switch(es) from Generac Power System's GTS line of digitally controlled transfer switches. In addition, Generac Power Systems' Genlink® Communications Software provides remote monitoring and user interface with the Power Manager Digital Control Platform.
- Values given are maximum temperatures to which power adjustment factors can be applied. Consult your Generac representative if operating conditions exceed these maximums.

# STANDARD ENGINE & SAFETY FEATURES

MD400 MPS

- High Coolant Temperature Automatic Shutdown
- Low Coolant Level Automatic Shutdown
- Low Oil Pressure Automatic Shutdown
- Overspeed Automatic Shutdown (Solid-state)
- Crank Limiter (Solid-state)
- Oil Drain Extension
- Radiator Drain
- Factory-Installed Cool Flow Radiator
- Radiator Duct Adapter On Open Genset
- Closed Coolant System
- UV/Ozone Resistant Hoses
- Rubber-Booted Engine Electrical Connections
- Stainless Steel Flexible Exhaust Connection
- Battery Charge Alternator
- Battery Cables
- Battery Tray
- 24 Volt, Solenoid-activated Starter Motor
- Air Cleaner
- Fan Guard
- Control Console
- Isochronous Governor
- Jacket water heater
- Autosynchronizer
- Isochronous Load Sharing Module
- Reverse Power Protection Relay
- Dead Bus Sensing
- Sync Check Relay
- Main Line Circuit Breaker
- 2 Year Warranty

## POWERMANAGER® DIGITAL CONTROL PLATFORM

The PowerManager Paralleling Controller (PM-PC) is a fully programmable, integrated digital generator control console using a 32-bit industrial microprocessor to handle all control, monitoring, input/output genset functions. The open architecture used allows customizing the controls to meet any customer requirement, yet maintaining the simplicity of operating 'as is' with the factory default programming. (see Generac bulletin #0168840SBY)

## GENERATOR CONNECTIONS

1. 4 Wire load connections from Paralleling Switch to optional connection box bus or transfer switch bus. Paralleling Switch has 4 lugs per phase – each lug will accept 4/0 to 350MCM aluminum or copper conductor.
2. 2 wire shielded cable (RS485) to PowerManager System Control.
3. 2 wire twisted pair from transfer switch (when multiple transfer switches are used). Can also go to the PowerManager System Controller
4. 120Volt 15 amp input circuit for battery charger.
5. 240Volt 20 amp input for coolant heater.

## OPTIONS

### ■ OPTIONAL FUEL ACCESSORIES

- Base Tank Low Fuel Alarms
- Secondary Fuel Filters, Heaters and Water Alarms
- UL Listed Fuel Tanks / Daytanks
- Electric Fuel Transfer Pump System

### ■ OPTIONAL ELECTRICAL ACCESSORIES

- 10A Dual Rate Battery Charger
- Battery, 24 Volt
- Battery Warmer

### ■ OPTIONAL ALTERNATOR ACCESSORIES

- Alternator Heater

### ■ OPTIONAL EXHAUST ACCESSORIES

- Critical Exhaust Silencer (Standard on enclosed gensets)

### ■ GENERAC POWERMANAGER® SYSTEM CONTROLLER FOR COORDINATION OF GENERATOR(S) AND TRANSFER SWITCH(ES)

- See Spec 0169060SBY For Additional Information

### ■ ADDITIONAL OPTIONAL EQUIPMENT

- 21 Light Remote Annunciator
- Remote Relay Panels
- Oil Heater
- 5 Year Warranties
- GenLink® Communications Software

### ■ OPTIONAL ENCLOSURES

- Weather Protective with Enclosed Mufflers
- Sound Attenuated with Enclosed Mufflers
- Aluminum

Distributed by:

Design and specifications subject to change without notice. Dimensions shown are approximate. Contact your Generac dealer for certified drawings. DO NOT USE THESE DIMENSIONS FOR INSTALLATION PURPOSES.

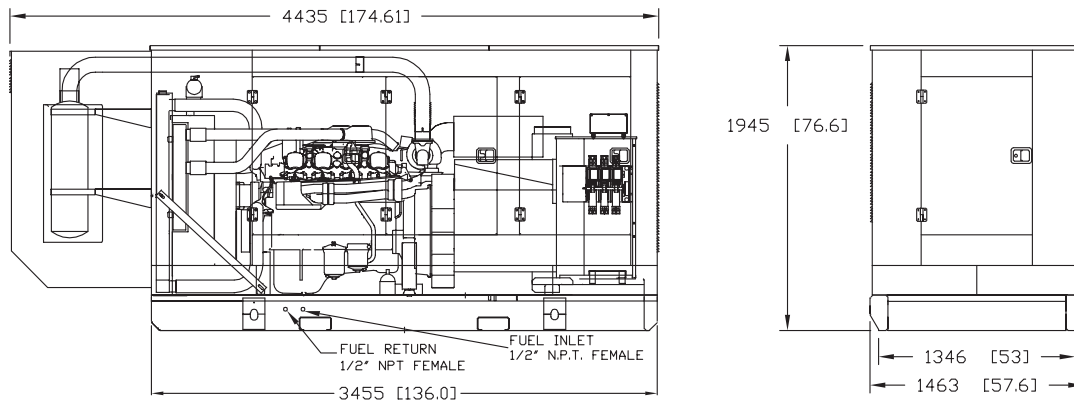

**GENERAC®**

Generac Power Systems, Inc. • S45 W29290 HWY. 59, Waukesha, WI 53189 • generac.com

©2009 Generac Power Systems, Inc. All rights reserved. All specifications are subject to change without notice. Bulletin 0168790SBY/Printed in U.S.A. 10.03, rev. 03.09