

# MB300

For Generac Modular Power System (MPS)

Standby Power Rating  
300KW 60 Hz

120/208, 277/480, 345/600 Volt  
**Bi-Fuel Diesel**

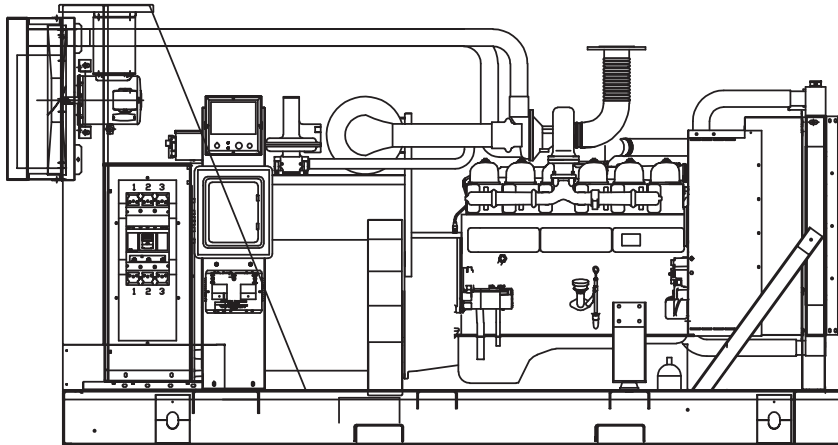

Natural Gas With Diesel Pilot Ignition

**GENERAC 12.0DTA ENGINE**  
Turbocharged, Aftercooled

PowerManager® Digital Control Platform

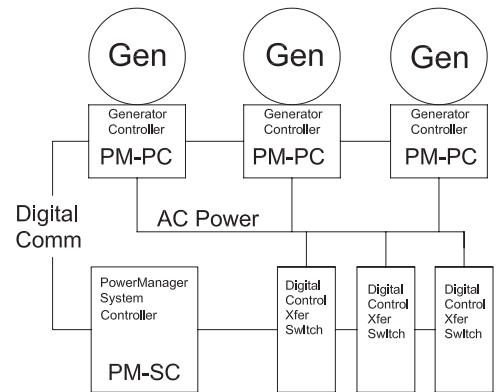

## FEATURES

- **INNOVATIVE DESIGN & PROTOTYPE TESTING** are key components of GENERAC'S success in "IMPROVING POWER BY DESIGN." But it doesn't stop there. Total commitment to component testing, reliability testing, environmental testing, destruction and life testing, plus testing to applicable CSA, NEMA, EGSA, and other standards, allows you to choose GENERAC POWER SYSTEMS with the confidence that these systems will provide superior performance.
- **PARALLELING SYSTEM FEATURES:**
  - ✓ AUTO SYNCHRONIZATION
  - ✓ ISOCHRONOUS LOAD SHARING
  - ✓ REVERSE POWER PROTECTION
  - ✓ MAXIMUM POWER PROTECTION
  - ✓ ELECTRICALLY OPERATED MECHANICALLY HELD TRANSFER SYSTEM
  - ✓ REDUNDANT OPERATION AND INCREASED RELIABILITY
  - ✓ UL2200 LISTED
- **POWERMANAGER® DIGITAL CONTROL PLATFORM.** The PowerManager® Digital Control Platform (PM-DCP) is a powerful control system built around a 32 bit industrial microprocessor. Standard factory programming controls the entire engine generator system while allowing the PM-DCP, with its onboard PLC, to be customized to meet any application requirement. The system is available on single unit gas, diesel or bi-fuel installations as well as Modular Paralleling Systems (MPS) from 200 kW - 3000 kW.
- **SOLID STATE DIGITAL VOLTAGE REGULATOR** senses all 3 phases, electronically matches surge loads to the torque curve of the engine.
- **BI-FUEL** provides low cost, low volume fuel storage and operation.
- **ECONOMICAL POWER.** Microprocessor controlled bi-fuel diesel/natural gas engine provides long, low cost, reliable life.
- **LONGER ENGINE LIFE.** Generac heavy-duty bi-fuel diesels provide long and reliable operating life.
- **SINGLE SOURCE SERVICE RESPONSE** from Generac's dealer network provides parts and service know-how for the entire unit, from the engine to the smallest electronic component. You are never on your own when you own a GENERAC POWER SYSTEM.
- **GENERAC TRANSFER SWITCHES, SWITCHGEAR AND ACCESSORIES.** Long life and reliability is synonymous with GENERAC POWER SYSTEMS. One reason for this confidence is that the GENERAC product line includes its own transfer systems, accessories, switchgear and controls for total system compatibility.

# GENERAC®

# APPLICATION & ENGINEERING DATA

MB300

## GENERATOR SPECIFICATIONS

TYPE ..... Four-pole, revolving field  
 ROTOR INSULATION ..... Class H  
 STATOR INSULATION ..... Class H  
 ADDITIONAL INSULATION ..... Antifungal Coating  
 TOTAL HARMONIC DISTORTION ..... <5%  
 TELEPHONE INTERFERENCE FACTOR (TIF) ..... <50  
 BEARINGS ..... Prelubed and Sealed  
 COUPLING ..... Direct Connected  
 LOAD CAPACITY(Standby Rating) ..... 100%  
 TEMPERATURE RISE ..... 125° C  
 WINDING PITCH ..... 2/3  
 ROTOR ..... Dynamically Balanced

### VOLTAGE REGULATOR

Regulation ..... Digitally Controlled ± 0.25%  
 Sensing ..... Single or 3 Phase  
 Paralleling Capability ..... Yes

### CONTROL PANEL

Type ..... PowerManager Digital Control Platform

### DISPLAY

AC Volts ..... Line to Line and Line to Neutral  
 AC Amps ..... Per line  
 Frequency ..... 10-99 Hertz  
 Oil Pressure ..... Digital Touchscreen LCD  
 Coolant Temperature ..... Digital Touchscreen LCD  
 Fuel Level ..... Digital Touchscreen LCD  
 DC Battery Voltage ..... Digital Touchscreen LCD  
 Hour Meter - Run Time Hours ..... Digital Touchscreen LCD  
 Engine Speed in RPM ..... Digital Touchscreen LCD  
 Generator Power kW ..... Digital Touchscreen LCD  
 Power Factor ..... Digital Touchscreen LCD  
 Turbo Pressure ..... Digital Touchscreen LCD  
 Gas Pressure ..... Digital Touchscreen LCD  
 Gas Flow (CFM) ..... Digital Touchscreen LCD  
 Air Temperature (Incoming) ..... Digital Touchscreen LCD  
 Gas Temperature ..... Digital Touchscreen LCD  
 Charge Air Cooler Valve Position ..... Digital Touchscreen LCD  
 Not in Auto ..... Digital Touchscreen LCD  
 Common Alarm ..... Digital Touchscreen LCD

### ALARMS

High/Low Generator Voltage ..... Digital Touchscreen LCD  
 High/Low Battery Voltage ..... Digital Touchscreen LCD  
 High/Low Frequency ..... Digital Touchscreen LCD  
 Low Oil Pressure & Prealarm ..... Digital Touchscreen LCD  
 High, Low, Critical Low Fuel Level ..... Digital Touchscreen LCD  
 Overcrank ..... Digital Touchscreen LCD  
 Sensor Failure ..... Digital Touchscreen LCD

### COMMUNICATION

Serial Communication RS232 and RS485  
 GenLink Software for PowerManager® Digital Control Platform

## ENGINE SPECIFICATIONS

MAKE ..... Generac / Mitsubshi  
 MODEL ..... 12.0DTA  
 CYLINDERS ..... 6 in-line  
 DISPLACEMENT ..... 11.945 Liter (729 cu. in.)  
 BORE ..... 130 mm (5.11 in.)  
 STROKE ..... 150 mm (5.91 in.)  
 COMPRESSION RATIO ..... 16.5:1  
 INTAKE AIR ..... Turbocharged, Aftercooled  
 NUMBER OF MAIN BEARINGS ..... 7  
 CONNECTING RODS ..... 6-Carbon Steel

Rating definitions - Standby: Applicable for supplying emergency power for the duration of the utility power outage. No overload capability is available for this rating. (All ratings in accordance with BS5514, ISO3046 and DIN6271).

## ENGINE SPECIFICATIONS Cont.

CYLINDER HEAD ..... (6) 1-Cylinder Cast Iron with Overhead Valve  
 PISTONS ..... Heat Resistant Aluminum Alloy  
 CRANKSHAFT ..... Case Hardened, Die Forged, Carbon Steel

### VALVE TRAIN

LIFTER TYPE ..... Solid  
 INTAKE VALVE MATERIAL ..... Stellite Faced Heat Resistant Steel  
 EXHAUST VALVE MATERIAL ..... Stellite Faced Heat Resistant Steel  
 HARDENED VALVE SEATS ..... Replaceable

### ENGINE GOVERNOR

ELECTRONIC ..... Standard  
 FREQUENCY REGULATION, NO-LOAD TO FULL LOAD ..... 0.5%  
 STEADY STATE REGULATION ..... ±0.25%

### LUBRICATION SYSTEM

TYPE OF OIL PUMP ..... Gear  
 OIL FILTER ..... Bypass and Full flow, cartridge  
 CRANKCASE CAPACITY ..... 31 Liters (8.2 U.S. gal.)

## ENGINE FEATURES

**ECONOMICAL POWER** Microprocessor controlled bi-fuel diesel engine starts on diesel fuel and provides power from an air/natural gas mixture ignited by diesel injection and continuously monitored by the on board control.

**LONGER ENGINE LIFE** Generac heavy duty bi-fuel diesels provide long and reliable operating life along with low emissions.

**EMISSIONS** Capable of low particulate and NOx emission levels. Unit is registered with SCAQMD permitting program (CEP No. 414037)

### HOW DOES A BI-FUEL ENGINE WORK?

The diesel engine is equipped with a metering system that feeds natural gas into the incoming air supply. The standard diesel injection pump is used and the injector sprays diesel fuel into the cylinder at the correct time. The diesel fuel ignites and thus ignites the natural gas charge. Total power is derived from a combination of natural gas and diesel as shown in the chart below. The ratio of natural gas to diesel fuel is a function of several factors, including load and intake air temperature. The system is programmed to avoid pre-ignition, but should it occur due to a transient event such as sudden loading or fuel variation, knock sensors will signal the controller to reduce the flow of natural gas and the diesel injectors will take over to maintain engine speed and required power level. The higher thermal efficiency of diesel engines and the lower cost of natural gas, along with low emission levels, combine to make the bi-fuel engine a very economical choice.

### FUEL PRESSURE - NAT. GAS 2 psi MINIMUM FUEL CONSUMPTION\*

		Diesel				Diesel	
kW	NG ft <sup>3</sup> /hr.	gal./hr.	kW	NG ft <sup>3</sup> /hr.	gal./hr.	kW	gal./hr.
125	1272	2.48	250	2617	2.0		
175	1832	1.41	300	2504	5.32		

Fuel Pressure NG line 2 psi @ full load BTU Content (Min) 920 BTU/ft<sup>3</sup> LHV

\*Note: Percentages and consumption can vary depending on air temperature and heat content of fuel

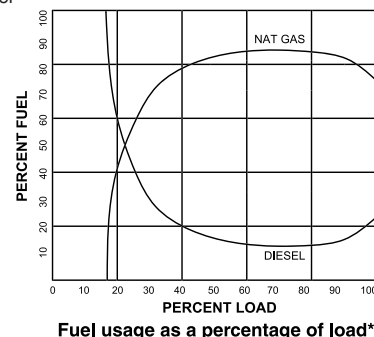

Fuel usage as a percentage of load\*

## OPERATING DATA

	STANDBY	
	MB300	
<b>GENERATOR OUTPUT VOLTAGE/KW-60Hz</b>	<b>kW</b>	<b>Rated AMP</b>
120/208V, 3-phase	288	1000
277/480V, 3-phase, 0.8 pf	300	452
600V, 3-phase, 0.8 pf	300	360
<b>MOTOR STARTING KVA</b>	<b>480V</b>	
Maximum at 35% instantaneous voltage dip with standard alternator; 60 Hz	1092	
with optional alternator; 60 Hz	1410	
<b>COOLING</b>		
Coolant capacity	System - US gal.	10.6
	Engine - US gal.	5.8
	Radiator - US gal.	4.8
Coolant flow/min.	60 Hz - US gal.	59.4
Heat rejection to coolant	- BTU/hr.	895,000
Radiator air flow	60 Hz - cfm	17,400
Alternator air flow	60 Hz - cfm	1080
Maximum external pressure drop after radiator	"H <sub>2</sub> O	0.5
Maximum operating air temperature onto radiator	°F	140 **
Maximum operating ambient temperature	°F	122 **
<b>COMBUSTION AIR REQUIREMENTS</b>		
Flow at rated power	60 Hz - cfm	886
<b>EXHAUST</b>		
Exhaust flow at rated output	60 Hz - cfm	2494
Max recommended back pressure	"Hg	1.5
Exhaust temperature at rated output (pre-turbo)	°F	1330
Exhaust outlet size		5" ANSI Flange
<b>ENGINE</b>		
Rated RPM	60 Hz	1800
HP at rated kW <sub>e</sub> (gross)	60 Hz	437
Piston speed	60 Hz - ft./min.	1772
BMEP	60 Hz psi	264
<b>POWER ADJUSTMENT FOR AMBIENT CONDITIONS</b>		
Temperature		
-2.5% for every 10°F above - °F		104
Altitude		
-2.5% for every 1000 ft. above - ft.		3500

## SYSTEM DESCRIPTION

Multiple generators are paralleled to a common generator bus through a unit-mounted switching mechanism to provide the total power output. The control system consists of the PowerManager® Digital Control Platform (PM-DCP) along with a PowerManager® Parallel Controller (PM-PC) for each 300 kW genset. The PowerManager System Controller (PM-SC) is provided in a separate NEMA 1 wall mount enclosure. It interfaces with the generator controllers to provide start-stop commands based on utility power, proportional load sharing and provides safe paralleling of each unit to the common generator bus.

The PowerManager Digital Control System, including generator controllers, can be locally or remotely viewed and programmed via Generac GenLink® Communications software. PowerManager also offers upstream digital communications via RS485/Modbus to other supervisory control systems.

## TYPICAL OPERATIONAL SEQUENCE

1. A transfer switch detects a utility failure and issues a start command. The command goes to the PM-SC which then issues a start command to the Generator Controller (PM-PC).
2. Each individual generator will start on its own.
3. The first generator that attains rated frequency and voltage is connected to the common generator bus via the switching mechanism.
4. The second generator will synchronize and close into the bus via its switching mechanism.
5. When all gensets are paralleled to the bus, the PM-SC will signal the transfer switch or switches to transfer to the load. There is a maximum of 3 programmed steps available for connection of multiple transfer switches.
6. If an NFPA requirement for 10 second start exists, the first unit up will connect to the bus. This causes the controller in a separate emergency transfer switch to immediately transfer to the NFPA load.
7. If a single generator fails, load shed contacts are available to disconnect selected noncritical loads.
8. If load conditions are reduced (night time operation) one generator can be programmed off-line (optional).
9. When utility supply returns, the PM-SC will issue commands to transfer loads back to the utility. It then issues commands to the individual PM-PC to disconnect from the bus. Each PM-PC will operate its generator for the cool-down period and then issue a shutdown command.

\*\*Note: Values given are maximum temperatures to which power adjustment factors can be applied. Consult your Generac representative if operating conditions exceed these maximums.

- High Coolant Temperature Automatic Shutdown w/Pre Alarms
- Low Coolant Level Automatic Shutdown w/Pre Alarms
- Low Oil Pressure Automatic Shutdown w/Pre Alarms
- Overspeed Automatic Shutdown (Solid-state)
- Crank Limiter (Solid-state Programmable)
- Oil Drain Extension
- Radiator Drain Extension
- Factory-Installed Cool Flow Radiator
- Closed Coolant Recovery System
- UV/Ozone Resistant Hoses
- Rubber-Booted Engine Electrical Connections
- Secondary Fuel Filter
- Fuel Lockoff Solenoid
- Stainless Steel Flexible Exhaust Connection
- Battery Charge Alternator
- Battery Cables
- Battery Tray
- Vibration Isolation of Unit to Mounting Base
- 24 Volt, Solenoid-activated Starter Motor
- Air Cleaner (dry type)
- Fan Guard
- Control Console
- Coolant Heater, 240V
- Isochronous Governor
- Radiator Duct Adapter
- Low Gas Pressure Alarm
- GenLink® Communications Software

## POWERMANAGER® DIGITAL CONTROL PLATFORM

The PowerManager® Paralleling Controller (PM-PC) is a fully programmable, integrated digital generator control console, using a 32-bit industrial microprocessor to handle all the control, monitoring, input and output genset functions. The open architecture used allows customizing the control to meet any customer requirement, yet maintaining the simplicity of operating 'as is' with the factory default programming. (see Generac bulletin #0168840SBY)

## OPTIONS

- **OPTIONAL COOLING SYSTEM ACCESSORIES**
  - Coolant Heater 120V
- **OPTIONAL FUEL ACCESSORIES**
  - Flexible Fuel Lines
  - UL Listed Base Tank
  - Base Tank Low Fuel Alarm
  - Secondary Diesel Fuel Filters and Heaters
- **OPTIONAL EXHAUST ACCESSORIES**
  - Critical Exhaust Silencer
- **OPTIONAL ELECTRICAL ACCESSORIES**
  - Battery, 12 Volt, 925 CCA, 31 (2 req'd)
  - Battery, 12 Volt, 1155 CCA, 8D (2 req'd)
  - 10A Dual Rate Battery Charger
  - Battery Heater
- **OPTIONAL ALTERNATOR ACCESSORIES**
  - Alternator Strip Heater
  - Alternator Tropicalization
- **ADDITIONAL OPTIONAL EQUIPMENT**
  - Automatic Transfer Switch
- **ADDITIONAL OPTIONAL EQUIPMENT (CONT.)**
  - 21 Light Remote Annunciator
  - Remote Relay Panel
  - Unit Vibration Isolators (Spring)
  - 5 Year Warranties
  - Export Boxing
- **OPTIONAL ENCLOSURES**
  - Weather Protective
  - Sound Attenuated
  - Aluminum and Stainless Steel
  - Enclosed Muffler

Distributed by:

