

SB375

Liquid Cooled Bi-Fuel Diesel Engine Generator Sets

Standby Power Rating
375KW 60 Hz

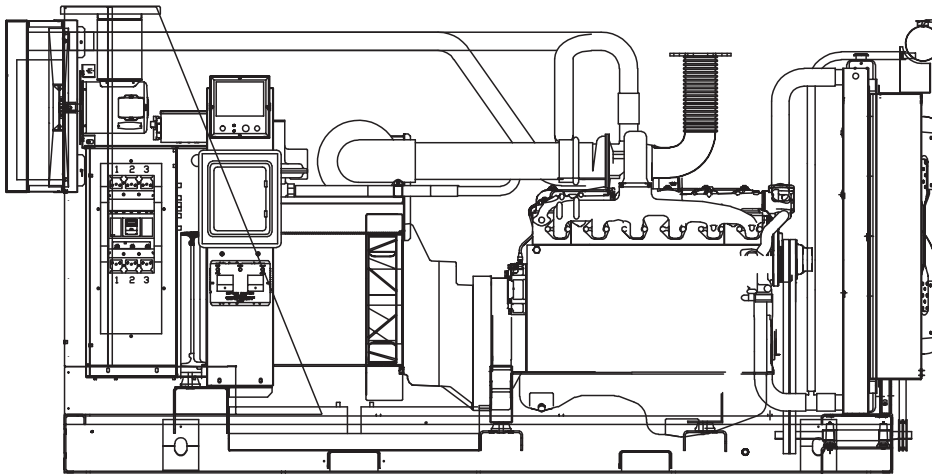

Power Matched

GENERAC 12.0DTA ENGINE

Turbocharged, Aftercooled
Diesel/Natural Gas Powered

FEATURES

- **INNOVATIVE DESIGN & PROTOTYPE TESTING** are key components of GENERAC'S success in "IMPROVING POWER BY DESIGN." But it doesn't stop there. Total commitment to component testing, reliability testing, environmental testing, destruction and life testing, plus testing to applicable CSA, NEMA, EGSA, and other standards, allows you to choose GENERAC POWER SYSTEMS with the confidence that these systems will provide superior performance.
- **TEST CRITERIA:**
 - ✓ PROTOTYPE TESTED
 - ✓ SYSTEM TORSIONAL TESTED
 - ✓ ELECTRO-MAGNETIC INTERFERENCE
 - ✓ NEMA MG1 EVALUATION
 - ✓ MOTOR STARTING ABILITY
 - ✓ SHORT CIRCUIT TESTING
 - ✓ UL 2200 LISTED
- **POWERMANAGER® DIGITAL CONTROL PLATFORM.** The PowerManager® Digital Control Platform (PM-DCP) is a powerful control system built around a 32 bit industrial microprocessor. Standard factory programming controls the entire engine generator system while allowing the PM-DCP, with its onboard PLC, to be customized to meet any application requirement. The system is available on single unit gas, diesel or bi-fuel installations as well as Modular Paralleling Systems (MPS) from 200 kW - 3000 kW.
- **SINGLE SOURCE SERVICE RESPONSE** from Generac's dealer network provides parts and service know-how for the entire unit, from the engine to the smallest electronic component. You are never on your own when you own a GENERAC POWER SYSTEM.
- **ECONOMICAL POWER.** Microprocessor controlled bi-fuel diesel engine starts on diesel fuel and provides power from an air/natural gas mixture ignited by the diesel injectors.
- **LONGER ENGINE LIFE.** Generac heavy-duty bi-fuel diesels provide long and reliable operating life.
- **GENERAC TRANSFER SWITCHES, SWITCHGEAR AND ACCESSORIES.** Long life and reliability is synonymous with GENERAC POWER SYSTEMS. One reason for this confidence is that the GENERAC product line includes its own transfer systems, accessories, switchgear and controls for total system compatibility.

GENERAC®

GENERATOR SPECIFICATIONS

TYPE	Four-pole, revolving field
ROTOR INSULATION	Class H
STATOR INSULATION	Class H
TOTAL HARMONIC DISTORTION	<3%
TELEPHONE INTERFERENCE FACTOR (TIF)	<50
ALTERNATOR	Self-ventilated and drip-proof
BEARINGS (PRE-LUBED & SEALED)	1
COUPLING	Direct, Flexible Disc

NOTE: Emergency loading in compliance with NFPA 99, NFPA 110, paragraph 5-13.2.6. Generator rating and performance in accordance with ISO8528-5, BS5514, SAE J1349, ISO3046 and DIN6271 standards.

EXCITATION SYSTEM

PERMANENT MAGNET EXCITER	Eighteen-pole exciter ✓
	Magnetically coupled DC current ✓
REGULATION	Digital Solid-state ✓
	±0.25% regulation ✓

GENERATOR FEATURES

- Four pole, revolving field generator, connected to the engine shaft through a heavy-duty gear reduction unit for permanent alignment.
- Generator meets the temperature rise standards for class "F" insulation as defined by NEMA MG1-32.6, while the insulation system meets the requirements for the higher class "H" rating.
- All prototype models have passed a three-phase symmetrical short circuit test to assure system protection and reliability.
- All prototype models are tested for motor starting ability by measuring the instantaneous voltage dip with a waveform data acquisition system.
- All models utilize an advanced wire harness design for reliable interconnection within the circuitry.
- Magnetic circuit, including amortisseur windings, tooth and skewed stator design, provides a minimal level of waveform distortion and an electromagnetic interference level which meets accepted requirements for standard AM radio, TV, and marine radio telephone applications.
- Voltage waveform deviation, total harmonic content of the AC waveform, and T.I.F. (Telephone Influence Factor) have been evaluated to acceptable standards in accordance with NEMA MG1-32.
- Alternator is self-ventilated and drip-proof constructed.
- Fully life-tested protective systems, including "field circuit and thermal overload protection" and optional main-line circuit breakers capable of handling full output capacity.
- System torsional acceptability confirmed during prototype testing.

ENGINE SPECIFICATIONS

MAKE	Mitsubishi / GENERAC
MODEL	12.0DTA
CYLINDERS	6 in-line
DISPLACEMENT	11.945 Liter (729 cu. in.)
BORE	130 mm (5.11 in.)
STROKE	150 mm (5.91 in.)
COMPRESSION RATIO	15.5:1
INTAKE AIR	Turbocharged, Aftercooled
NUMBER OF MAIN BEARINGS	7
CONNECTING RODS	6-Carbon Steel
CYLINDER HEAD	(6) 1-Cylinder Cast Iron with Overhead Valve
PISTONS	6-Heat Resistant Aluminum Alloy
CRANKSHAFT	Case Hardened, Die Forged, Carbon Steel

VALVE TRAIN

LIFTER TYPE	Solid
INTAKE VALVE MATERIAL	Stellite Faced Heat Resistant Steel
EXHAUST VALVE MATERIAL	Stellite Faced Heat Resistant Steel
HARDENED VALVE SEATS	Replaceable

ENGINE GOVERNOR

<input type="checkbox"/> ELECTRONIC	Standard
FREQUENCY REGULATION, NO-LOAD TO FULL LOAD	0.5%
STEADY STATE REGULATION	±0.25%

LUBRICATION SYSTEM

TYPE OF OIL PUMP	Gear
OIL FILTER	Bypass and Full flow, cartridge
CRANKCASE CAPACITY	31 Liters (8.2 U.S. gal.)

COOLING SYSTEM

TYPE OF SYSTEM	Pressurized, closed recovery
WATER PUMP	Pre-lubed, self-sealing
TYPE OF FAN	Puller
NUMBER OF FAN BLADES	8
DIAMETER OF FAN	991 mm (39 in.)
COOLANT HEATER	240V, 2000 W

FUEL SYSTEM

FUEL	#2D Fuel (Min Cetane #40)
	(Fuel should conform to ASTM spec.)
FUEL	Natural Gas 2 psi Minimum
FUEL FILTER	10 Micron
FUEL INJECTION PUMP	Bosch PE6P Type
GAS INJECTOR	GENERAC
FUEL PUMP	Mechanical
INJECTORS	Multi-hole, nozzle type
ENGINE TYPE	Direct injection
FUEL LINE (Supply)	9.53 mm (0.375 in.)
FUEL RETURN LINE	9.53 mm (0.375 in.)
NATURAL GAS LINE	2" NPT

ELECTRICAL SYSTEM

BATTERY CHARGE ALTERNATOR	35 Amps at 24 V
STARTER MOTOR	24 V
RECOMMENDED BATTERY	700 CCA (2)—12V, 27f
GROUND POLARITY	Negative

OPERATING DATA

		STANDBY			
		SB375			
GENERATOR OUTPUT VOLTAGE/KW-60Hz 277/480V, 3-phase, 0.8 pf 600V, 3-phase, 0.8 pf		kW	Rated AMP		
		375	564		
		375	451		
MOTOR STARTING KVA Maximum at 35% instantaneous voltage dip with standard alternator; 60 Hz		208V	480V		
		960	1410		
COOLING					
Coolant capacity	System US gal.	20.8			
	Engine US gal.	5.8			
	Radiator US gal.	15.0			
Coolant flow/min.	60 Hz US gal.	180.5			
	50 Hz US gal.	150.4			
Heat rejection to coolant	BTU/hr.	1,265,000			
Inlet air	60 Hz cfm	35,000			
	50 Hz cfm	29,167			
Maximum operating air temperature onto radiator	°F	130 **			
Maximum operating ambient temperature	°F	122 **			
COMBUSTION AIR REQUIREMENTS					
Flow at rated power	60 Hz cfm	1257			
EXHAUST					
Exhaust flow at rated output	60 Hz cfm	4237			
Max recommended back pressure	Hg	1.5			
Exhaust temperature at rated output (pre-turbo)	°F	1350			
Exhaust outlet size		5" ANSI Flange			
ENGINE					
Rated RPM	60 Hz / 50 Hz	2280 / 1900			
HP at rated kW (gross)	60 Hz / 50 Hz	555 / 437			
Piston speed	60 Hz ft./min.	2248			
BMEP	60 Hz / 50 Hz - psi	264 / 249			
POWER ADJUSTMENT FOR AMBIENT CONDITIONS					
Temperature	°C	25	30	40	50
	°F	77	86	104	122
	Rating kW	750	750	750	648
Altitude	-0.8% for every 100 m above - m	1066			
	-2.5% for every 1000 ft. above - ft.	3500			

FUEL CONSUMPTION*

60 Hertz kW	Nat Gas ft ³ /hr	Diesel gal/hr
100	707	4.52
150	1507	3.12
200	2024	2.09
250	2617	2.01
300	3140	2.42
325	3400	2.62
350	3460	4.23
375	3358	6.95

Fuel Pressure NG line 2 psi @ full load BTU Content (Min) 920 BTU/ft³ LHV

*Note: Percentages and consumption can vary depending on air temperature and heat content of fuel

**Note: Values given are maximum temperatures to which power rating adjustments can be applied. Consult your Generac representative if operating conditions exceed these maximums.

ENGINE FEATURES

ECONOMICAL POWER Microprocessor controlled bi-fuel diesel engine starts on diesel fuel and provides power from an air/natural gas mixture ignited by diesel injection and continuously monitored by the on board control.

LONGER ENGINE LIFE Generac heavy duty bi-fuel diesels provide long and reliable operating life along with low emissions.

GENERAC GEAR DRIVE Generac's gear drive technology drives the engine at the most economical operating point. The engine runs at 2280 rpm which is well below the maximum design point. The brake mean effective pressure (BMEP) which is an indication of how hard the engine is working, is comparable to the SD300 which operates at 1800 rpm. The Generac gear drive transmission is constructed with heavy duty helical gears and ball bearings for quiet operation and long life. It has been thoroughly tested by Generac's engineering test facilities and in the field. It has been in the Generac product line for over 20 years and several thousand units are installed and in operation today.

EMISSIONS Capable of low particulate and NOx emission levels. Unit is registered with SCAQMD permitting program (CEP No. 414037)

HOW DOES A BI-FUEL ENGINE WORK?

The diesel engine is equipped with a metering system that feeds natural gas into the incoming air supply. The standard diesel injection pump is used and the injector sprays diesel fuel into the cylinder at the correct time. The diesel fuel ignites and thus ignites the natural gas charge. Total power is derived from a combination of natural gas and diesel as shown in the chart below. The ratio of natural gas to diesel fuel is a function of several factors, including load and intake air temperature. The system is programmed to avoid pre-ignition, but should it occur due to a transient event such as sudden loading or fuel variation, knock sensors will signal the controller to reduce the flow of natural gas and the diesel injectors will take over to maintain engine speed and required power level. The higher thermal efficiency of diesel engines and the lower cost of natural gas, along with low emission levels, combine to make the bi-fuel engine a very economical choice.

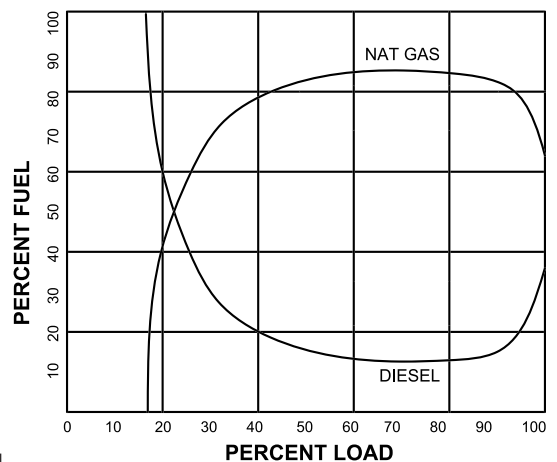

Fuel usage as a percentage of load*

STANDARD ENGINE & SAFETY FEATURES

SB375

- High Coolant Temperature Automatic Shutdown
- Low Coolant Level Automatic Shutdown
- Low Oil Pressure Automatic Shutdown
- Overspeed Automatic Shutdown (Solid-state)
- Crank Limiter (Solid-state)
- Oil Drain Extension
- Radiator Drain Extension
- Factory-Installed Cool Flow Radiator
- Closed Coolant Recovery System
- UV/Ozone Resistant Hoses
- Rubber-Booted Engine Electrical Connections
- Primary Fuel Filter
- Fuel Lockoff Solenoid
- Stainless Steel Flexible Exhaust Connection
- Battery Charge Alternator
- Battery Cables
- Battery Tray
- Vibration Isolation of Unit to Mounting Base
- 24 Volt, Solenoid-activated Starter Motor
- Air Cleaner
- Fan Guard
- Control Console
- Coolant Heater, 240V
- Isochronous Governor
- Radiator Duct Adapter
- Low Gas Pressure Alarm

POWERMANAGER® DIGITAL CONTROL PLATFORM

The PowerManager® Generator Controller (PM-GC) is a fully programmable, integrated digital generator control console, using a 32-bit industrial microprocessor to handle all the control, monitoring, input and output genset functions. The open architecture used allows customizing the control to meet any customer requirement, yet maintaining the simplicity of operating 'as is' with the factory default programming. (see Generac bulletin #0168840SBY)

OPTIONS

- **OPTIONAL COOLING SYSTEM ACCESSORIES**
 - Coolant Heater, 120V
- **OPTIONAL FUEL ACCESSORIES**
 - Flexible Fuel Lines
 - UL Listed Base Tank
 - Base Tank Low Fuel Alarm
 - Secondary Diesel Fuel Filters and Heaters
- **OPTIONAL EXHAUST ACCESSORIES**
 - Critical Exhaust Silencer (Std. on enclosed gensets)
- **OPTIONAL ELECTRICAL ACCESSORIES**
 - Battery, 12 Volt, 135 A.H., 4D (2 req'd)
 - Battery, 12 Volt, 225 A.H., 8D (2 req'd)
 - 10A Dual Rate Battery Charger
 - Battery Heater
- **OPTIONAL ALTERNATOR ACCESSORIES**
 - Alternator Strip Heater
 - Alternator Tropicalization
 - Main Line Circuit Breaker
- **ADDITIONAL OPTIONAL EQUIPMENT**
 - Automatic Transfer Switch
 - 21 Light Remote Annunciator
- Remote Relay Panel
- Unit Vibration Isolators (Spring)
- Oil Heater
- 5 Year Warranties
- Export Boxing
- GenLink® Communications Software
- **OPTIONAL ENCLOSURES**
 - Weather Protective with Enclosed Mufflers
 - Sound Attenuated with Enclosed Mufflers
 - Aluminum and Stainless Steel
 - Enclosed Muffler

Distributed by:

Design and specifications subject to change without notice. Dimensions shown are approximate. Contact your Generac dealer for certified drawings. DO NOT USE THESE DIMENSIONS FOR INSTALLATION PURPOSES.

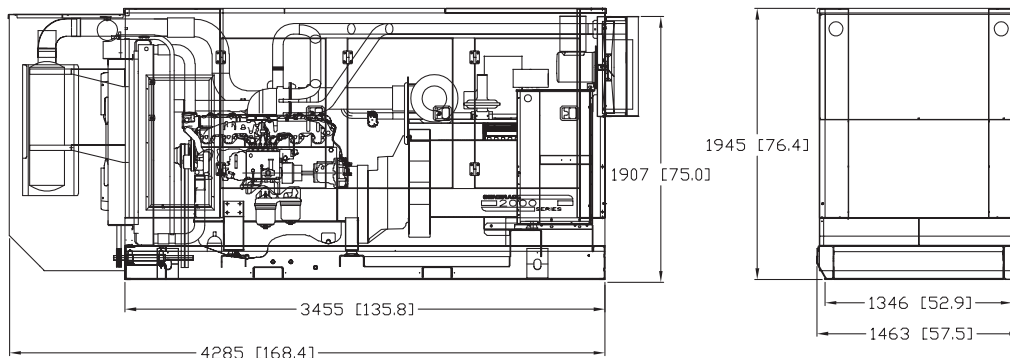

mm [in]

Shown with standard weather protective enclosure

GENERAC®

Generac Power Systems, Inc. • S45 W29290 HWY. 59, Waukesha, WI 53189 • generac.com

©2008 Generac Power Systems, Inc. All rights reserved. All specifications are subject to change without notice. Bulletin 0169230SBY-B / Printed in U.S.A. 09/09/10