

MG 150

Generac Modular Power System (MPS)

Standby Power Rating
150KW 60 Hz

Power Matched

GENERAC 13.3GTA ENGINE

Turbocharged/Aftercooled
Gas Engine Generator
Meets 2009 EPA Emission Regulations

PowerManager® Digital Control Platform

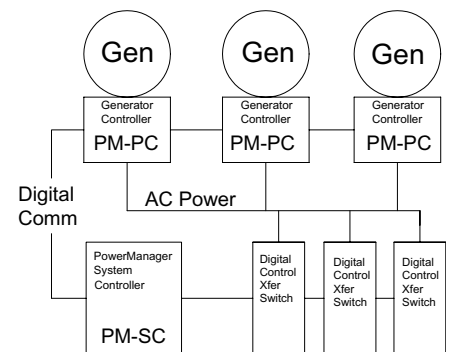
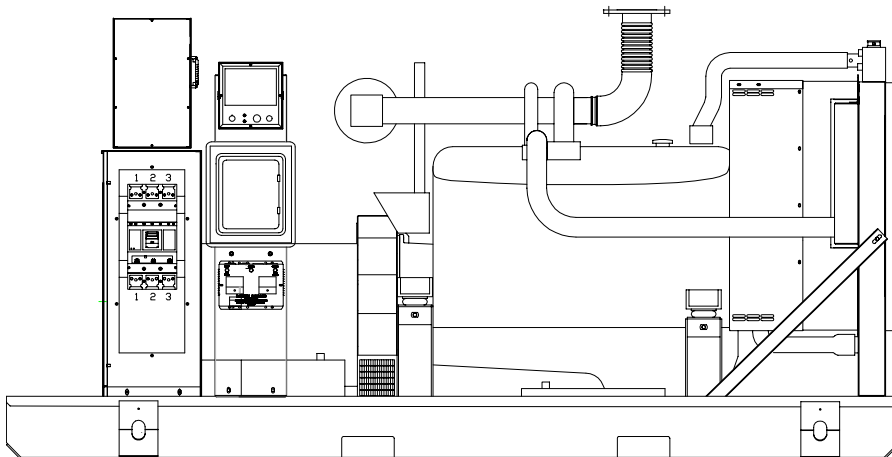

FEATURES

- **INNOVATIVE DESIGN & PROTOTYPE TESTING** are key components of GENERAC'S success in "IMPROVING POWER BY DESIGN." But it doesn't stop there. Total commitment to component testing, reliability testing, environmental testing, destruction and life testing, plus testing to applicable CSA, NEMA, EGSA, and other standards, allows you to choose GENERAC POWER SYSTEMS with the confidence that these systems will provide superior performance.
- **PARALLELING SYSTEM FEATURES:**
 - ✓ AUTO SYNCHRONIZATION
 - ✓ ISOCHRONOUS LOAD SHARING
 - ✓ REVERSE POWER PROTECTION
 - ✓ MAXIMUM POWER PROTECTION
 - ✓ ELECTRICALLY OPERATED MECHANICALLY HELD TRANSFER SYSTEM
 - ✓ REDUNDANT OPERATION AND INCREASED RELIABILITY
 - ✓ UL2200 LISTED
- **POWERMANAGER DIGITAL CONTROL PLATFORM™.** The PowerManager Digital Control Platform (PM-DCP) is a powerful control system built around a 32-bit, industrial microprocessor. Standard factory programming controls the entire engine/generator

system, while allowing the PM-DCP, with its onboard PLC, to be customized to meet any application requirement. The system is available on single unit gas, diesel or bi-fuel installations as well as Modular Power Systems (MPS) from 350 kW - 3000 kW.

- **SINGLE SOURCE SERVICE RESPONSE** from Generac's dealer network provides parts and service know-how for the entire unit, from the engine to the smallest electronic component. You are never on your own when you own a GENERAC POWER SYSTEM.
- **ECONOMICAL NATURAL GAS POWER.** Low cost operation due to modern gas engine technology. Better fuel utilization plus lower cost per kW provide real savings.
- **LONGER ENGINE LIFE.** Generac heavy-duty natural gas engines provide long and reliable operating life.
- **GENERAC TRANSFER SWITCHES, POWERMANAGER™ AND ACCESSORIES.** Long life and reliability is synonymous with GENERAC POWER SYSTEMS. One reason for this confidence is that the GENERAC product line includes its own transfer systems, accessories, and PowerManager™ controls for total system compatibility.

GENERAC®

APPLICATION & ENGINEERING DATA

MG150

GENERATOR SPECIFICATIONS

TYPE	Four-pole, revolving field
ROTOR INSULATION	Class H
STATOR INSULATION	Class H
TOTAL HARMONIC DISTORTION	<3%
TELEPHONE INTERFERENCE FACTOR (TIF)	<30
SHORT CIRCUIT CURRENT	300%
ALTERNATOR	Self-ventilated and drip-proof
BEARINGS (PRE-LUBED & SEALED)	1
COUPLING	Direct, Flexible Disc
LOAD CAPACITY (STANDBY)	100%

NOTE: Generator rating and performance in accordance with ISO8528-5, BS5514, SAE J1349, ISO3046 and DIN6271 standards.

EXCITATION SYSTEM

PERMANENT MAGNET EXCITER	Eighteen pole exciter ✓
	Magnetically coupled DC current ✓
	Mounted outboard of main bearing ✓
REGULATION	Digital Solid-state ✓
	±1% regulation ✓

CONTROL SYSTEM PM-PC (See Note 5)

The Generac PowerManager™ Paralleling control is mounted at the generator set and monitors all engine and alternator parameters:

- High/Low Battery
- High/Low Frequency
- High Oil Temp
- Pre-alarm Hi Oil Temp
- Low Oil Pressure
- Pre-alarm Lo Oil Pressure
- Low Coolant Level
- Overcrank
- Overspeed/Underspeed
- Pre-alarm Hi Coolant
- Sensor Failures
- Critical Low Fuel
- Over/Under Voltage
- Lo Fuel Pressure
- Sensor Failures

The instrumentation screen displays the following:

- AC volts
- AC amps
- Frequency
- kW
- Power Factor
- Coolant Temp
- Coolant level
- Run time hours
- Fuel level(%)
- Battery Voltage
- Oil Pressure
- Engine Speed

■ Serial Communication to the PowerManager Integrated Controller or System Controller via RS485 connection

■ Programmable

■ Built in Synchronizer for paralleling control and protection

■ Digital Voltage Regulator for concise control

■ Three Pole 1000amp paralleling switch

- Rated 600 volts
- UL Recognized device
- Electrically Operated - Mechanically held
- Built in arc suppression

■ Mainline Circuit Breaker

Mounted in series with paralleling switch

■ Generator Connection Box

Mounted on right side (facing rear) 12" x 22" x 36"

Access from side, top, bottom to paralleling switch

ENGINE SPECIFICATIONS

MAKE	GENERAC
MODEL	13.3GTA
CYLINDERS	6 in-line
DISPLACEMENT	13.3 Liter (811 cu. in.)
BORE	137 mm (5.39 in.)
STROKE	150 mm (5.91 in.)
COMPRESSION RATIO	10.5:1
INTAKE AIR	Turbocharged/Aftercooled
NUMBER OF MAIN BEARINGS	7
CONNECTING RODS	6-Carbon Steel
CYLINDER HEAD	Cast Iron with Overhead Valve
CYLINDER LINERS	Wet/Replaceable
IGNITION	Altronic CD1
PISTONS	Heat-Resistant Alloy with 4 Rings
CRANKSHAFT	Induction-Hardened, Die-Forged Carbon Steel

VALVE TRAIN

LIFTER TYPE	Solid
INTAKE VALVE MATERIAL	Special Heat Resistant Steel
EXHAUST VALVE MATERIAL	Inconel Alloy High Temp.
HARDENED VALVE SEATS	High Temp. Alloy Stellite Faced

ENGINE GOVERNOR

ELECTRONIC	Standard
FREQUENCY REGULATION, NO-LOAD TO FULL LOAD	0.5%
STEADY STATE REGULATION	±0.25%

LUBRICATION SYSTEM

TYPE OF OIL PUMP	Gear Driven
OIL FILTER	Full flow, cartridge
CRANKCASE CAPACITY	27 Liters (7.13 gal.)

COOLING SYSTEM

TYPE OF SYSTEM	Pressurized, closed recovery
WATER PUMP	Pre-lubed, self-sealing
TYPE OF FAN	Pusher
NUMBER OF FAN BLADES	6
DIAMETER OF FAN	30 in.
COOLANT HEATER	2-240V, 1000 W

FUEL SYSTEM

FUEL	<input type="checkbox"/> Natural Gas..... Standard
CARBURETOR	Down draft
SECONDARY FUEL REGULATOR	Nat. Gas
AUTOMATIC FUEL LOCKOFF SOLENOID	Standard
OPERATING FUEL PRESSURE SYSTEMS	7" to 15" H ₂ O
MINIMUM BTU / ft ³	875
INPUT PIPE SIZE	1 1/2" NPT

ELECTRICAL SYSTEM

BATTERY CHARGE ALTERNATOR	20 Amps at 24 V
STARTER MOTOR	24 V
RECOMMENDED BATTERY	925 CCA (2) - 12 V, 135 A.H., 4D
GROUND POLARITY	Negative

MG150

OPERATING DATA		STANDBY	
		MG150	
GENERATOR OUTPUT VOLTAGE/KW-60Hz		N.G.	Rated AMP
120/208V, 3-phase, 0.8 pf	NOTE: Consult your Generac dealer for additional voltages.	150	520
277/480V, 3-phase, 0.8 pf		150	225
600V, 3-phase, 0.8 pf		150	180
MOTOR STARTING KVA			
Maximum at 35% instantaneous voltage dip with standard alternator — 60 Hz		208V	480V
with optional alternator — 60 Hz		348 kVA	464 kVA
		900 kVA	1356 kVA
FUEL		N.G.	
Fuel consumption—60 Hz—100% Load			
	ft. ³ hr.		1850
COOLING			
Coolant capacity	System - US gal.		7.7
	Engine - US gal.		5.6
	Radiator - US gal.		2.1
Coolant flow/min.	60 Hz - US gal.		45
Heat rejection to coolant			558,000
Inlet air	60 Hz - cfm		17,400
Max. operating air temperature on radiator	°F		140
Max. operating ambient temperature	°F		122
Max. external pressure drop on radiator	" H ₂ O		0.5
COMBUSTION AIR REQUIREMENTS			
Flow at rated power		60 Hz - cfm	480
EXHAUST			
Exhaust flow at rated output		60 Hz - cfm	1490
Max recommended back pressure		Hg	1.5"
Exhaust temp at rated output		°F	1210
Exhaust outlet size		I.D. (flange)	4"
ENGINE			
Rated RPM		60 Hz	1800
HP at rated KW		60 Hz	309
Piston speed		60 Hz - ft./min.	1773
BMEP		60 Hz – psi	168
DERATION FACTORS			
Temperature			
	2.77% for every 10°F above - °F		110
Altitude			
	3.5% for every 1000 ft. above - ft.		7500

Notes:

- Motor Starting kVA adds directly for each generator on the bus. With Generac's PowerManager® Control System, the load is shared proportionally.
- Maximum distance between Generator Sets is determined by the voltage drop of the power conductors and the maximum distance allowed for the RS485 connection. If the Distance between units exceeds **500 feet**, consult factory for wire and communication recommendations.
- Fuel consumption like motor starting kVA is additive. Each Generator will proportionally share the load and the fuel consumption will be based on the percentage of load shared.
- A complete MPS system requires a PowerManager Paralleling Controller (PM-PC), a PowerManager System Controller (PM-SC), and switch(es) from Generac Power System's GTS line of digitally controlled transfer switches. In addition, Generac Power Systems' Genlink® Communications Software provides remote monitoring and user interface with the Power Manager Digital Control Platform.
- Values given are maximum temperatures to which power adjustment factors can be applied. Consult your Generac representative if operating conditions exceed these maximums.
- MPS Gensets are available for Standby Applications Only, at this time.

- High Coolant Temperature Automatic Shutdown
- Low Coolant Level Automatic Shutdown
- Low Oil Pressure Automatic Shutdown
- Overspeed Automatic Shutdown (Solid-state)
- Crank Limiter (Solid-state)
- Oil Drain Extension
- Radiator Drain
- Factory-Installed Cool Flow Radiator
- Closed Coolant System
- UV/Ozone Resistant Hoses
- Rubber-Booted Engine Electrical Connections
- Stainless Steel Flexible Exhaust Connection
- Battery Charge Alternator
- Battery Cables
- Battery Tray
- 24 Volt, Solenoid-activated Starter Motor
- Air Cleaner
- Fan Guard
- Control Console
- Isochronous Governor
- Jacket water heater
- Autosynchronizer
- Isochronous Load Sharing Module
- Reverse Power Protection Relay
- Dead Bus Sensing
- Sync Check Relay
- Main Line Circuit Breaker
- 2 Year Warranty
- Engine Coolant Heater

GENERATOR CONNECTIONS

1. 4 Wire load connections on Paralleling Contactor: Each phase will accept (4) #6 to 350MCM aluminum or copper conductor.
2. 2 wire shielded cable (RS485) to Power Manager System Control or Power Manager Integral Control
3. 2 wire Twisted pair from Transfer switch (when multiple transfer switches are used) Can also go to the Power Manager System Controller
4. 120 Volt 15 amp input circuit for Battery Charger.
5. 240 Volt 20 amp input for Coolant Heater.

OPTIONS

■ OPTIONAL COOLING SYSTEM ACCESSORIES

- Radiator Duct Adapter

■ OPTIONAL FUEL ACCESSORIES

- Flex Fuel Lines
- Low Pressure Alarm

■ OPTIONAL ELECTRICAL ACCESSORIES

- 10A Dual Rate Battery Charger
- Battery, 24 Volt
- Battery warmer

■ OPTIONAL ALTERNATOR ACCESSORIES

- Alternator Heater

■ OPTIONAL EXHAUST ACCESSORIES

- Critical Exhaust Silencer

■ GENERAC POWERMANAGER™ INTEGRATED

- Controller and ATS Note 5 - See Spec 0167390SBY for additional information

■ GENERAC POWERMANAGER™ SYSTEM

- Controller Note 5 for Multiple Transfer Switches See Spec 0167380SBY for Additional Information

■ ADDITIONAL OPTIONAL EQUIPMENT

- 20 Light Remote Annunciator
- Remote Relay Panels
- Oil Make-Up System
- Oil Heater
- GenLink® Communications Software

■ OPTIONAL ENCLOSURES

- Weather Protective
- Sound Attenuated
- Aluminum and Stainless Steel

Distributed by:

