

# MG250

For Generac Modular Power Systems (MPS)

Standby Power Rating  
250 KW 60 Hz

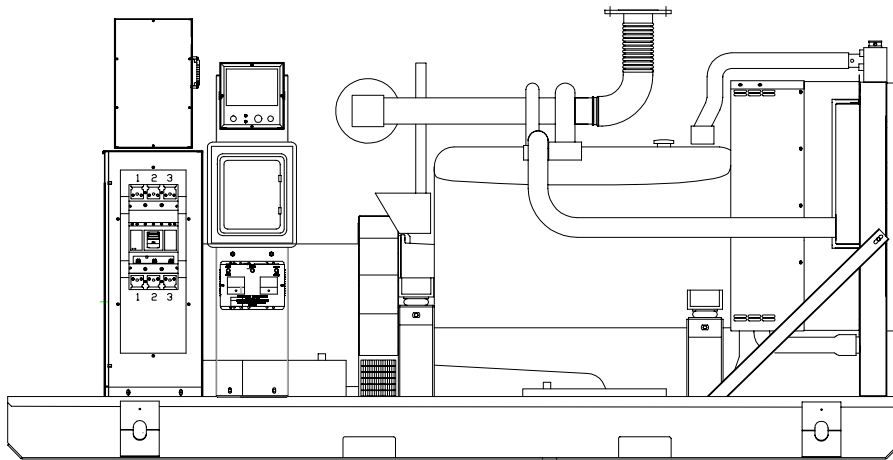

Power Matched

**GENERAC 13.3GTA ENGINE**

Turbocharged/Aftercooled  
Gas Engine Generator  
Meets EPA Emission Regulations

PowerManager® Digital Control Platform

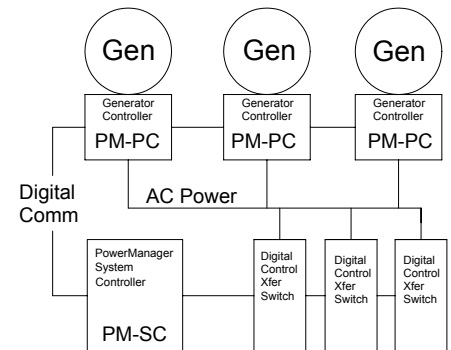

## FEATURES

- **INNOVATIVE DESIGN & PROTOTYPETESTING** are key components of GENERAC'S success in "IMPROVING POWER BY DESIGN." But it doesn't stop there. Total commitment to component testing, reliability testing, environmental testing, destruction and life testing, plus testing to applicable CSA, NEMA, EGSA, and other standards, allows you to choose GENERAC POWER SYSTEMS with the confidence that these systems will provide superior performance.
- **PARALLELING SYSTEM FEATURES:**
  - ✓ AUTO SYNCHRONIZATION
  - ✓ ISOCHRONOUS LOAD SHARING
  - ✓ REVERSE POWER PROTECTION
  - ✓ MAXIMUM POWER PROTECTION
  - ✓ ELECTRICALLY OPERATED MECHANICALLY HELD TRANSFER SYSTEM
  - ✓ REDUNDANT OPERATION AND INCREASED RELIABILITY
  - ✓ UL2200 LISTED
  - ✓ PARALLEL UP TO 10 UNITS
- **POWERMANAGER® DIGITAL CONTROL PLATFORM.** The PowerManager Digital Control Platform (PM-DCP) is a powerful control system built around a 32-bit, industrial microprocessor. Standard factory programming controls the entire engine/generator

system, while allowing the PM-DCP, with its onboard PLC, to be customized to meet any application requirement. The system is available on single unit gas, diesel or bi-fuel installations as well as Modular Power Systems (MPS) from 200 kW - 6000 kW.

- **SINGLE SOURCE SERVICE RESPONSE** from Generac's dealer network provides parts and service know-how for the entire unit, from the engine to the smallest electronic component. You are never on your own when you own a GENERAC POWER SYSTEM.
- **ECONOMICAL NATURAL GAS POWER.** Low cost operation due to modern gas engine technology. Better fuel utilization plus lower cost per kW provide real savings.
- **LONGER ENGINE LIFE.** Generac heavy-duty natural gas engines provide long and reliable operating life.
- **GENERAC TRANSFER SWITCHES, POWERMANAGER® AND ACCESSORIES.** Long life and reliability is synonymous with GENERAC POWER SYSTEMS. One reason for this confidence is that the GENERAC product line includes its own transfer systems, accessories, and PowerManager™ controls for total system compatibility.

# GENERAC®

# APPLICATION & ENGINEERING DATA

MG250

## GENERATOR SPECIFICATIONS

TYPE .....	Four-pole, revolving field
ROTOR INSULATION.....	Class H
STATOR INSULATION.....	Class H
TOTAL HARMONIC DISTORTION .....	<3%
TELEPHONE INTERFERENCE FACTOR (TIF).....	<30
SHORT CIRCUIT CURRENT .....	300%
ALTERNATOR .....	Self-ventilated and drip-proof
BEARINGS (PRE-LUBED & SEALED) .....	1
COUPLING.....	Direct, Flexible Disc
LOAD CAPACITY (STANDBY) .....	100%

**NOTE: Generator rating and performance in accordance with ISO8528-5, BS5514, SAE J1349, ISO3046 and DIN6271 standards.**

### EXCITATION SYSTEM

PERMANENT MAGNET EXCITER .....	Eighteen pole exciter ✓
	Magnetically coupled DC current ✓
	Mounted outboard of main bearing ✓
REGULATION.....	Digital Solid-state ✓
	±1% regulation ✓

## CONTROL SYSTEM PM-GC (See Note 5)

The Generac PowerManager™ Generator control is mounted at the generator set and monitors all engine and alternator parameters:

- High/Low Battery
- High Oil Temp
- Low Oil Pressure
- Low Coolant Level
- High Coolant Level
- Low Coolant Level
- Overspeed/Underspeed
- Sensor Failures
- High/Low Frequency
- Pre-alarm Hi Oil Temp
- Pre-alarm Lo Oil Pressure
- Overcrank
- Pre-alarm Hi Coolant
- Critical Low Fuel
- Over/Under Voltage
- Lo Fuel Pressure

The instrumentation screen displays the following:

- AC volts
- Frequency
- Power Factor
- Coolant level
- Fuel level(%)
- Oil Pressure
- AC amps
- kW
- Coolant Temp
- Run time hours
- Battery Voltage
- Engine Speed

■ Serial Communication to the PowerManager Integral controller or System Controller via RS485 connection

■ Programmable

■ Built in Synchronizer for paralleling control and protection

■ Digital Voltage Regulator for concise control

■ Three Pole 1000amp paralleling switch

- Rated 600 volts
- UL Recognized device
- Electrically Operated - Mechanically heald
- Built in ARC supression

■ Mainline Circuit Breaker

Mounted in series with paralleling switch

■ Generator Connection Box

Mounted on right side (facing rear) 12" x 22" x 36"

Access from side, top, bottom to paralleling switch

## ENGINE SPECIFICATIONS

MAKE .....	GENERAC
MODEL.....	13.3GTA
CYLINDERS.....	6 in-line
DISPLACEMENT.....	13.3 Liter (811 cu. in.)
BORE .....	137 mm (5.39 in.)
STROKE.....	150 mm (5.91 in.)
COMPRESSION RATIO .....	10.5:1
INTAKE AIR .....	Turbocharged/Aftercooled
NUMBER OF MAIN BEARINGS .....	7
CONNECTING RODS .....	6-Carbon Steel
CYLINDER HEAD .....	Cast Iron with Overhead Valve
CYLINDER LINERS .....	Wet/Replaceable
IGNITION.....	Altronic CD1
PISTONS.....	Heat-Resistant Alloy with 4 Rings
CRANKSHAFT .....	Induction-Hardened, Die-Forged Carbon Steel

### VALVE TRAIN

LIFTER TYPE .....	Solid
INTAKE VALVE MATERIAL.....	Special Heat Resistant Steel
EXHAUST VALVE MATERIAL .....	Inconel Alloy High Temp.
HARDENED VALVE SEATS .....	High Temp. Alloy Stellite Faced

### ENGINE GOVERNOR

ELECTRONIC .....	Standard
FREQUENCY REGULATION, NO-LOAD TO FULL LOAD .....	0.5%
STEADY STATE REGULATION.....	±0.25%

### LUBRICATION SYSTEM

TYPE OF OIL PUMP .....	Gear Driven
OIL FILTER.....	Full flow, cartridge
CRANKCASE CAPACITY.....	27 Liters (7.13 gal.)

### COOLING SYSTEM

TYPE OF SYSTEM .....	Pressurized, closed recovery
WATER PUMP.....	Pre-lubed, self-sealing
TYPE OF FAN .....	Pusher
NUMBER OF FAN BLADES.....	8
DIAMETER OF FAN .....	39 in.
COOLANT HEATER.....	1-240V, 2000 W

### FUEL SYSTEM

FUEL	<input type="checkbox"/> Natural Gas..... Standard
CARBURETOR.....	Down draft
SECONDARY FUEL REGULATOR.....	Nat. Gas
AUTOMATIC FUEL LOCKOFF SOLENOID.....	Standard
OPERATING FUEL PRESSURE.....	11" to 15" H <sub>2</sub> O
MINIMUM BTU (ft <sup>3</sup> ).....	875
INPUT PIPE SIZE.....	1 1/2" NPT

### ELECTRICAL SYSTEM

BATTERY CHARGE ALTERNATOR.....	20 Amps at 24 V
STARTER MOTOR .....	24 V
RECOMMENDED BATTERY.....	925 CCA (2) - 12 V, 135 A.H., 4D
GROUND POLARITY.....	Negative

Rating definitions - Standby: Applicable for supplying emergency power for the duration of the utility power outage. No overload capability is available for this rating. (All ratings in accordance with BS5514, ISO3046 and DIN6271). Prime : Applicable for supplying electric power in lieu of commercially purchased power. Prime power is the maximum power available at variable load. A 10% overload capacity is available for 1 hour in 12 hours. (All ratings in accordance with BS5514, ISO3046, ISO8528 and DIN6271).

## MG250

OPERATING DATA	STANDBY	
	MG250	
<b>GENERATOR OUTPUT VOLTAGE/KW-60Hz</b> 120/208V, 3-phase, 0.8 pf 277/480V, 3-phase, 0.8 pf 600V, 3-phase, 0.8 pf <small>NOTE: Consult your Generac dealer for additional voltages.</small>	<b>N.G.</b> 250 250 250	<b>Rated AMP</b> 868 376 301
<b>MOTOR STARTING KVA</b> Maximum at 35% instantaneous voltage dip with standard alternator — 60 Hz with optional alternator — 60 Hz	<b>208V</b> 692 kVA 794 kVA	<b>480V</b> 922 kVA 1059 kVA
<b>FUEL</b> Fuel consumption—60 Hz—Natural Gas* ft. <sup>3</sup> hr.		<b>N.G.</b> 906 1557 2253 3000 3790
<b>COOLING</b> Coolant capacity System - US gal. Coolant flow/min. 60 Hz - US gal. Heat rejection to coolant Inlet air 60 Hz - cfm Max. operating air temperature on radiator °F Max. operating ambient temperature °F Max. external pressure drop on radiator " H <sub>2</sub> O		15 45 915,100 19,200 140 120 0.5
<b>COMBUSTION AIR REQUIREMENTS</b> Flow at rated power 60 Hz - cfm		1060
<b>EXHAUST</b> Exhaust flow at rated output 60 Hz - cfm Max recommended back pressure Hg Exhaust temp at rated output °F Exhaust outlet size I.D. (flange)		3776 1.5" 1460 4"
<b>ENGINE</b> Rated RPM 60 Hz HP at rated KW** 60 Hz Piston speed 60 Hz - ft./min. BMEP 60 Hz - psi		2300 385 2265 163
<b>DERATION FACTORS</b> Temperature 1.1% for every 10°F above - °F Altitude 2.1% for every 1000 ft. above - ft.		110 4500

\* Refer to "Emissions Data Sheets" for maximum fuel flow for EPA and SCAQMD permitting purposes.

\*\* Refer to "Emissions Data Sheets" for maximum bHP for EPA and SCAQMD permitting purposes.

### Notes:

1. Motor Starting kVA adds directly for each generator on the bus. With Generac's PowerManager® Control System, the load is shared proportionally.
2. For Additional voltages consult factory.
3. Maximum distance between Generator Sets is determined by the voltage drop of the power conductors and the maximum distance allowed for the RS485 connection. If the Distance between units exceeds **500** feet, consult factory for wire and communication recommendations.
4. Fuel consumption like motor starting kVA is additive. Each Generator will proportionally share the load and the fuel consumption will be based on the percentage of load shared.
5. For complete system operation, the MPS requires either the Power Manager Integral Control (**PM-IC**) which is part of the Generac Power Manager Automatic Transfer Switch or the Power Manager System Control (**PM-SC**) which is a separate enclosure and connects to multiple transfer switches with 2 wire start. Up to 3 separate switches or 3 groups of multiple switches can be controlled individually.
6. MPS Gensets are available for Standby Applications Only, at this time.

- High Coolant Temperature Automatic Shutdown
- Low Coolant Level Automatic Shutdown
- Low Oil Pressure Automatic Shutdown
- Overspeed Automatic Shutdown (Solid-state)
- Crank Limiter (Solid-state)
- Oil Drain Extension
- Radiator Drain
- Factory-Installed Cool Flow Radiator
- Closed Coolant System
- UV/Ozone Resistant Hoses
- Rubber-Booted Engine Electrical Connections
- Stainless Steel Flexible Exhaust Connection
- Battery Charge Alternator
- Battery Cables
- Battery Tray
- 24 Volt, Solenoid-activated Starter Motor
- Air Cleaner
- Fan Guard
- Control Console
- Isochronous Governor
- Jacket water heater
- Autosynchronizer
- Isochronous Load Sharing Module
- Reverse Power Protection Relay
- Dead Bus Sensing
- Sync Check Relay
- Main Line Circuit Breaker
- 2 Year Warranty
- Engine Coolant Heater

## GENERATOR CONNECTIONS

1. 4 Wire load connections on Paralleling Contactor: Each phase will accept (4) #6 to 350MCM aluminum or copper conductor.
2. 2 wire shielded cable (RS485) to Power Manager System Control or Power Manager Integral Control
3. 2 wire Twisted pair from Transfer switch ( when multiple transfer switches are used) Can also go to the Power Manager System Controller
4. 120 Volt 15 amp input circuit for Battery Charger.
5. 240 Volt 20 amp input for Coolant Heater.

## OPTIONS

- **OPTIONAL COOLING SYSTEM ACCESSORIES**
  - Radiator Duct Adapter
- **OPTIONAL FUEL ACCESSORIES**
  - Flex Fuel Lines
  - Low Pressure Alarm
- **OPTIONAL ELECTRICAL ACCESSORIES**
  - 10A Dual Rate Battery Charger
  - Battery, 24 Volt
  - Battery warmer
- **OPTIONAL ALTERNATOR ACCESSORIES**
  - Alternator Heater
- **OPTIONAL EXHAUST ACCESSORIES**
  - Critical Exhaust Silencer
- **GENERAC POWERMANAGER® INTEGRATED**
  - Controller and ATS Note 5 - See Spec 0167390SBY for additional information
- **GENERAC POWERMANAGER® SYSTEM**
  - Controller Note 5 for Multiple Transfer Switches See Spec 0167380SBY for Additional Information
- **ADDITIONAL OPTIONAL EQUIPMENT**
  - 20 Light Remote Annunciator
  - Remote Relay Panels
  - Oil Make-Up System
  - Oil Heater
  - GenLink® Communications Software
- **OPTIONAL ENCLOSURES**
  - Weather Protective
  - Sound Attenuated
  - Aluminum and Stainless Steel

Distributed by:

