

SD350

Liquid Cooled Diesel Engine Generator Sets

Standby Power Rating
350 kW 60 Hz

Prime Power Rating
317 kW 60 Hz

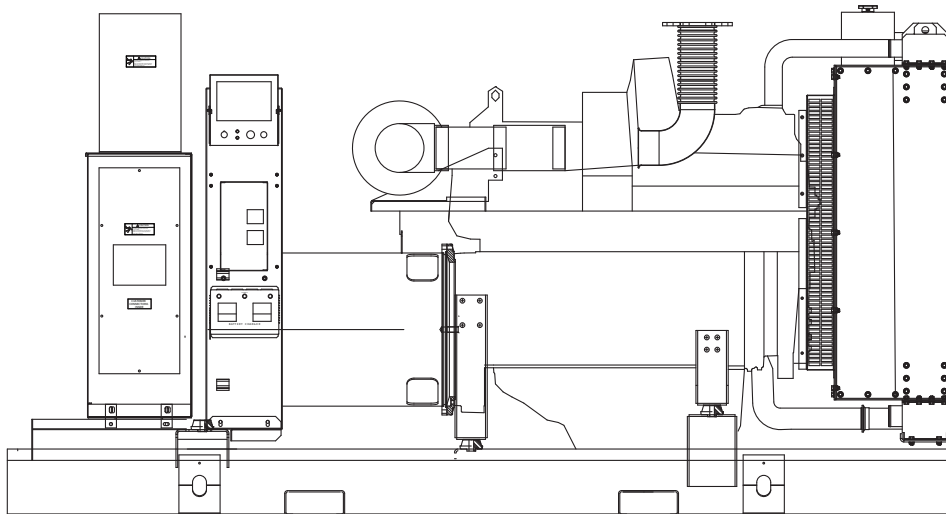

Power Matched
13.5L Deere Engine
Turbocharged / Aftercooled
Tier III Compliant

FEATURES

- **INNOVATIVE DESIGN & PROTOTYPE TESTING** are key components of GENERAC'S success in "IMPROVING POWER BY DESIGN." But it doesn't stop there. Total commitment to component testing, reliability testing, environmental testing, destruction and life testing, plus testing to applicable CSA, NEMA, EGSA, and other standards, allows you to choose GENERAC POWER SYSTEMS with the confidence that these systems will provide superior performance.
- **TEST CRITERIA:**
 - ✓ PROTOTYPE TESTED
 - ✓ SYSTEM TORSIONAL TESTED
 - ✓ ELECTRO-MAGNETIC INTERFERENCE
 - ✓ NEMA MG1 EVALUATION
 - ✓ MOTOR STARTING ABILITY
 - ✓ SHORT CIRCUIT TESTING
 - ✓ UL 2200 COMPLIANCE AVAILABLE
 - ✓ TIER III COMPLIANCE
- **POWERMANAGER® DIGITAL CONTROL PLATFORM.** The PowerManager® Digital Control Platform (PM-DCP) is a powerful control system built around a 32-bit, industrial microprocessor. Standard factory programming controls the entire engine / generator system, while allowing the PM-DCP, with its onboard PLC, to be customized to meet any application requirement. The system is available on single unit gas, diesel or bi-fuel installations as well as Modular Paralleling Systems (MPS) from 350 kW - 3000 kW.
- **SINGLE SOURCE SERVICE RESPONSE** from Generac's dealer network provides parts and service know-how for the entire unit, from the engine to the smallest electronic component. You are never on your own when you own a GENERAC POWER SYSTEM.
- **ECONOMICAL DIESEL POWER.** Low cost operation due to modern diesel engine technology. Better fuel utilization plus lower cost per gallon provide real savings.
- **LONGER ENGINE LIFE.** Deere heavy-duty diesels provide long and reliable operating life.
- **GENERAC TRANSFER SWITCHES, SWITCHGEAR AND ACCESSORIES.** Long life and reliability is synonymous with GENERAC POWER SYSTEMS. One reason for this confidence is that the GENERAC product line includes its own transfer systems, accessories, switchgear and controls for total system compatibility.

GENERAC®

GENERATOR SPECIFICATIONS

TYPE	Four-pole, revolving field
ROTOR INSULATION	Class H
STATOR INSULATION	Class H
LINE-TO-LINE HARMONIC FACTOR	5%
BALANCED TELEPHONE INFLUENCE FACTOR (TIF)	<50
ALTERNATOR	Self-ventilated and drip-proof
BEARINGS (PRE-LUBED & SEALED)	1
COUPLING	Direct, Flexible Disc
LOAD CAPACITY (STANDBY)	100%
LOAD CAPACITY (PRIME)	110%

NOTE: Emergency loading in compliance with NFPA 99, NFPA 110. Generator rating and performance in accordance with ISO8528-5, BS5514, SAE J1349, ISO3046 and DIN6271 standards.

EXCITATION SYSTEM

- PERMANENT MAGNET PILOT EXCITER..... Eighteen-pole exciter ✓
 - Magnetically coupled DC current ✓
 - Mounted outboard of main bearing ✓
- REGULATION..... H100 Controller Digital ✓
 - 3 Phase Sensing, ± 1% regulation ✓

GENERATOR FEATURES

- Revolving field heavy duty generator
- Directly connected to the engine
- Operating temperature rise 120 °C above a 40 °C ambient
- Insulation is Class H rated at 150 °C rise
- All prototype models have passed three phase short circuit testing

CONTROL PANEL FEATURES

- TOUCH SCREEN DISPLAY PANEL READS:
 - Voltage (all phases)
 - Power factor
 - kVAR
 - Engine speed
 - Run hours
 - Fault history
 - Coolant temperature
 - Low oil pressure shutdown
 - Overvoltage
 - Low coolant level
 - Not in auto position (flashing light)
 - ATS selection
 - Current (all phases)
 - kW
 - Transfer switch status
 - Low fuel pressure
 - Service reminders
 - Oil pressure
 - Time and date
 - High coolant temperature shutdown
 - Overspeed
 - Low coolant level
 - Exercise speed
- INTERNAL FUNCTIONS:
 - I²T function for alternator protection from line to neutral and line to line short circuits
 - Emergency stop
 - Programmable auto crank function
 - 2 wire start for any transfer switch
 - Communicates with the Generac HTS transfer switch
 - Built-in 7 day exerciser
 - Adjustable engine speed at exerciser
 - RS232 port for GenLink® control
 - RS485 port remote communication
 - Canbus addressable
 - Governor controller and voltage regulator are built into the master control board
 - Temperature range -40 °C to 70 °C

ENGINE SPECIFICATIONS

MAKE	DEERE
MODEL	See Exhaust Emission Sheet
ENGINE FAMILY	First digit is Cert. Yr. (i.e. 7, 8, 9) _JDXL13.5103
CYLINDERS	I-6
DISPLACEMENT - liter/(cu. in.)	13.5 (824)
BORE - mm/(in.)	132 (5.20)
STROKE - mm/(in.)	165 (6.50)
COMPRESSION RATIO	16.0:1
INTAKE AIR	Turbocharged/Aftercooled
NUMBER OF MAIN BEARINGS	5
CONNECTING RODS	Carbon Steel
CYLINDER HEAD	Cast Iron with Overhead Valves
PISTONS	Heat Resistant Aluminum Alloy
CRANKCASE	Case Hardened, Die Forged, Carbon Steel
ENGINE CRANKCASE VENT	Open

VALVE TRAIN

LIFTER TYPE	Solid
INTAKE VALVE MATERIAL	Special Heat Resistant Steel
EXHAUST VALVE MATERIAL	Stellite Faced Heat Resistant Steel
HARDENED VALVE SEATS	Replaceable
VALVES PER CYLINDER	4

ENGINE GOVERNOR

ELECTRONIC	Standard
FREQUENCY REGULATION NO LOAD TO FULL LOAD	Isochronous
STEADY STATE FREQUENCY REGULATION	±0.25%

LUBRICATION SYSTEM

TYPE OF OIL PUMP	Gear
OIL FILTER	Bypass and Full Flow Cartridge
CRANKCASE CAPACITY - liter/(gal.)	60 (15.8)

COOLING SYSTEM

TYPE OF SYSTEM	Pressurized, Closed Recovery
WATER PUMP	Pre-Lubed, Self Sealing
TYPE OF FAN	Pusher
NUMBER OF FAN BLADES	8
DIAMETER OF FAN - mm/(in.)	966 (38.0)
COOLANT HEATER	240V(2000W)

FUEL SYSTEM

FUEL	No. 2 Diesel (Min. Cetane #40) (Fuel should conform to ASTM Spec.)
FUEL FILTER	10 Micron
FUEL INJECTION PUMP	Delphi EUI
INJECTORS	Multi-hole, Nozzle Type
FUEL LINE (Supply)	12.7 (0.50)
FUEL RETURN LINE	9.53 (0.375)
FUEL PUMP	Mechanical

ELECTRICAL SYSTEM

BATTERY CHARGE ALTERNATOR	60 Amps at 24V
STARTER MOTOR	8.0 kW at 24V
RECOMMENDED BATTERY	(2) 12V - 31
GROUND POLARITY	Negative

SD350

OPERATING DATA	STANDBY				PRIME																																																											
GENERATOR OUTPUT VOLTAGE/KW—60Hz 120/208V, 3-phase, 0.8 pf 120/240V, 3-phase, 0.8 pf 277/480V, 3-phase, 0.8 pf 346/600V, 3-phase, 0.8 pf <small>NOTE: Consult your Generac dealer for additional voltages.</small>	Rated kW		Rated AMP		Rated kW		Rated AMP																																																									
	350	350	350	350	1214	1052	526	421	317	317	317	317	1100	953	477	381																																																
MOTOR STARTING KVA Maximum @ 35% instantaneous voltage dip 60 Hz with Standard Alternator	208/240 V		480/600 V		208/240 V		480/600 V		900	1342	900	1342	900	1342	900	1342																																																
FUEL Fuel consumption—60 Hz % Load kW @ % Load gal./hr. liters/hr. Total fuel flow gal/hr. Maximum Fuel Return Press.	25%	50%	75%	100%	25%	50%	75%	100%	88	175	263	350	80	159	238	317	8.1	13.7	19.3	26.4	5.9	11.8	17.8	23.7	30.7	51.9	73.1	99.9	22.3	44.7	67.4	89.7																																
	45 - 47				45 - 47				140 In. H2O (5.1 PSI)				140 In. H2O (5.1 PSI)																																																			
COOLING Coolant capacity System - lit./gal. Engine - lit./gal. Radiator - lit./gal. Coolant flow/min. 60 Hz - lit./gal. Heat rejection to coolant BTU/hr. Inlet air 60 Hz - m ³ /min. (cfm) Max. air temp onto radiator* °C (°F) Max. ambient temperature* °C (°F)	64.5 (17.03)				64.5 (17.03)				18 (4.75)				18 (4.75)				46.5 (12.28)				46.5 (12.28)				470 (124)				470 (124)				662,520				621,540				567 (20,000)				567 (20,000)				60 (140)				60 (140)				50 (122)				50 (122)			
COMBUSTION AIR REQUIREMENTS Flow at rated power 60 Hz - m ³ /min. (cfm)	33 (1165)				30 (1059)				33 (1165)				30 (1059)																																																			
EXHAUST Exhaust flow at rated output 60 Hz - m ³ /min. (cfm) Maximum recommended back pressure Kpa (" Hg) Exhaust temperature at rated output °C (°F) Exhaust outlet size mm. (in)	75 (2649)				65 (2295)				10 (2.9)				10 (2.9)				446 (836)				417 (738)				127 (5")				127 (5")																																			
ENGINE Rated RPM 60 Hz HP at rated KW 60 Hz Piston speed 60 Hz - m/sec. (ft./min) BMEP 60 Hz psi	1800				1800				538				489				594 (1950)				594 (1950)				287				261																																			
POWER ADJUSTMENT FOR AMBIENT CONDITIONS Temperature -4.5% for every 10 °C above - °C -2.5% for every 10 °F above - °F Altitude -0.8% for every 100 m above - m -2.5% for every 1000 ft. above - ft.	40				40				104				104				1500				1500				5000				5000																																			

* Note: Values given are maximum temperatures to which power adjustments can be applied. Consult your Generac Power Systems representative if operating conditions exceed these maximums.

- High Coolant Temperature Automatic Shutdown
- Low Coolant Level Automatic Shutdown
- Low Oil Pressure Automatic Shutdown
- Overspeed Automatic Shutdown (Solid-state)
- Crank Limiter (Solid-state)
- Oil Drain Extension
- Radiator Drain Extension
- Factory-Installed Cool Flow Radiator
- Closed Coolant System
- UV/Ozone Resistant Hoses
- Rubber-Booted Engine Electrical Connections
- Stainless Steel Flexible Exhaust Connection
- Secondary Fuel Filter

- Fuel Lock Off Solenoid
- Battery Charge Alternator
- Battery Cables
- Battery Tray
- Vibration Isolation between Unit and Base Frame
- 24 Volt, Solenoid-activated Starter Motor
- Air Cleaner
- Fan Guard
- Control Console
- Isochronous Governor
- Jacket Water Heater
- Flexible Fuel Lines (Stainless Steel Braid)
- Radiator Duct Adaptor

POWERMANAGER® DIGITAL CONTROL PLATFORM

The PowerManager® Generator Controller (PM-GC) is a fully programmable, integrated digital generator control console using a 32-bit industrial microprocessor to handle all control, monitoring, input/output genset functions. The open architecture used allows customizing the controls to meet any customer requirement, yet maintaining the simplicity of operation 'as is' with the factory default programming. (see Generac bulletin #0168840SBY)

OPTIONS

■ OPTIONAL COOLING SYSTEM ACCESSORIES

- Optional Coolant Systems (consult factory)

■ OPTIONAL FUEL ACCESSORIES

- Base Tank Low Fuel Alarm
- Primary Fuel Filters
- UL Listed Fuel Tanks
- Electric Fuel Transfer Pump System

■ OPTIONAL ELECTRICAL ACCESSORIES

- 10A Dual Rate Battery Charger
- Battery, 24 Volt
- Battery Warmer

■ OPTIONAL ALTERNATOR ACCESSORIES

- Alternator Upsizing
- Alternator Heater
- Main Line Circuit Breaker
- Alternator Tropicalization

■ OPTIONAL ENCLOSURES

- Weather Protective
- Sound Attenuated
- Aluminum & Stainless Steel
- Enclosed Critical Muffler

■ ADDITIONAL OPTIONAL EQUIPMENT

- Automatic Transfer Switch (100 Amp - 2600 Amp)
- 20 Light Remote Annunciator
- Remote Relay Panels
- Oil Make-Up System
- Oil Heater
- 5 Year Warranties
- Export Boxing
- GenLink® Communications Software

Distributed by:

