

SD060

Liquid Cooled Diesel Engine Generator Sets

Standby Power Rating
60KW 60 Hz / 60KVA 50 Hz

Prime Power Rating
54KW 60 Hz / 54KVA 50 Hz

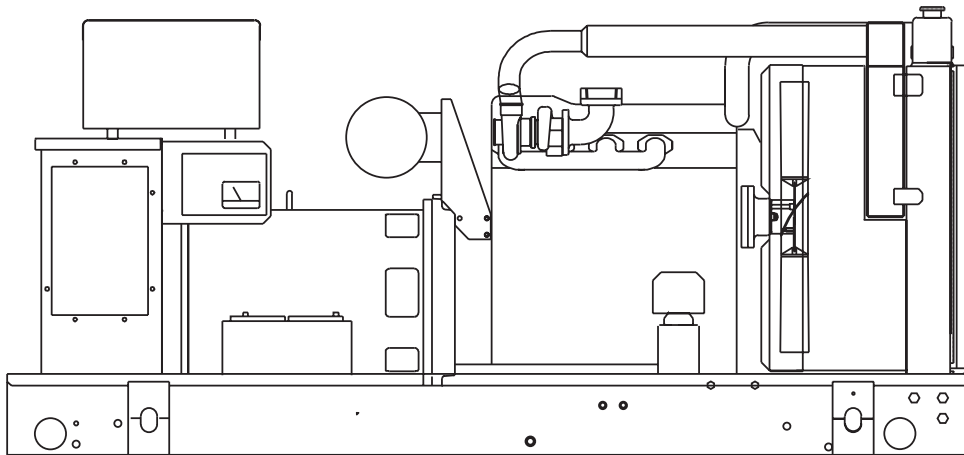

Power Matched
GENERAC 3.0DTA ENGINE
Turbocharged / Aftercooled
Tier III Compliant

FEATURES

- **INNOVATIVE DESIGN & PROTOTYPE TESTING** are key components of GENERAC'S success in "IMPROVING POWER BY DESIGN." But it doesn't stop there. Total commitment to component testing, reliability testing, environmental testing, destruction and life testing, plus testing to applicable CSA, NEMA, EGSA, and other standards, allows you to choose GENERAC POWER SYSTEMS with the confidence that these systems will provide superior performance.
- **TEST CRITERIA:**
 - ✓ PROTOTYPE TESTED
 - ✓ SYSTEM TORSIONAL TESTED
 - ✓ ELECTRO-MAGNETIC INTERFERENCE
 - ✓ NEMA MG1 EVALUATION
 - ✓ MOTOR STARTING ABILITY
 - ✓ SHORT CIRCUIT TESTING
 - ✓ UL COMPLIANCE AVAILABLE
- **SOLID-STATE, FREQUENCY COMPENSATED DIGITAL VOLTAGE REGULATION.** This state-of-the-art power maximizing regulation system is standard on all Generac models. It provides optimized FAST RESPONSE to changing load conditions and MAXIMUM MOTOR STARTING CAPABILITY by electronically torque-matching the surge loads to the engine.
- **SINGLE SOURCE SERVICE RESPONSE** from Generac's dealer network provides parts and service know-how for the entire unit, from the engine to the smallest electronic component. You are never on your own when you own a GENERAC POWER SYSTEM.
- **ECONOMICAL DIESEL POWER.** Low cost operation due to modern diesel engine technology. Better fuel utilization plus lower cost per gallon provide real savings.
- **LONGER ENGINE LIFE.** Generac heavy-duty diesels provide long and reliable operating life.
- **GENERAC TRANSFER SWITCHES, SWITCHGEAR AND ACCESSORIES.** Long life and reliability is synonymous with GENERAC POWER SYSTEMS. One reason for this confidence is that the GENERAC product line includes its own transfer systems, accessories, switchgear and controls for total system compatibility.

GENERAC®

GENERATOR SPECIFICATIONS

TYPE	Four-pole, revolving field
ROTOR INSULATION	Class H
STATOR INSULATION	Class H
TOTAL HARMONIC DISTORTION	<3%
TELEPHONE INTERFERENCE FACTOR (TIF)	<50
ALTERNATOR	Self-ventilated and drip-proof
BEARINGS (PRE-LUBED & SEALED)	1
COUPLING	Direct, Flexible Disc
LOAD CAPACITY (STANDBY)	100%
LOAD CAPACITY (PRIME)	110%

NOTE: Emergency loading in compliance with NFPA 99, NFPA 110. Generator rating and performance in accordance with ISO8528-5, BS5514, SAE J1349, ISO3046 and DIN6271 standards.

VOLTAGE REGULATOR

TYPE	Full Digital
SENSING	3 Phase
REGULATION	± 1/4%
FEATURES	Built into H-100 Control Panel, V/F Adjustable Adjustable Voltage and Gain

GENERATOR FEATURES

- Revolving field heavy duty generator
- Quiet drive coupling
- Operating temperature rise 120°C above a 40°C ambient
- Insulation is Class H rated at 150°C rise
- All prototype models have passed three phase short circuit testing

CONTROL PANEL FEATURES

- TWO FOUR LINE LCD DISPLAYS READ:
 - Voltage (all phases)
 - Power factor
 - kVAR
 - Engine speed
 - Run hours
 - Fault history
 - Coolant temperature
 - Low oil pressure shutdown
 - Overvoltage
 - Low coolant level
 - Exercise speed
 - Not in auto position (flashing light)
 - Current (all phases)
 - kW
 - Transfer switch status
 - Low fuel pressure
 - Service reminders
 - Oil pressure
 - Time and date
 - High coolant temp shutdown
 - Overspeed
 - Low coolant level
 - ATS selection
- INTERNAL FUNCTIONS:
 - I²T function for alternator protection from line to neutral and line to line short circuits
 - Emergency stop
 - Programmable auto crank function
 - 2 wire start for any transfer switch
 - Communicates with the Generac HTS transfer switch
 - Built-in 7 day exerciser
 - Adjustable engine speed at exerciser
 - RS232 port for GenLink[®] control
 - RS485 port remote communication
 - Canbus addressable
 - Governor controller and voltage regulator are built into the master control board
 - Temperature range -40°C to 70°C

ENGINE SPECIFICATIONS

MAKE	GENERAC/DEERE
MODEL	See Exhaust Emission Sheet
ENGINE FAMILY	First digit is Cert. Yr. (i.e. 7, 8, 9) _JDXL03.0113
CYLINDERS	5
DISPLACEMENT	3.0 Liter (186 cu.in.)
BORE	86mm (3.39 in.)
STROKE	105 mm (4.13 in.)
COMPRESSION RATIO	18:1
INTAKE AIR	Turbocharged/Aftercooled
NUMBER OF MAIN BEARINGS	5
CONNECTING RODS	5-Drop Forged Steel
CYLINDER HEAD	Cast Iron
PISTONS	5-Aluminum Alloy
CRANKSHAFT	Die Forged, Induction Hardened Steel

VALVE TRAIN

LIFTER TYPE	Solid
INTAKE VALVE MATERIAL	Heat Resistant Steel
EXHAUST VALVE MATERIAL	Heat Resistant Steel
HARDENED VALVE SEATS	Replaceable

ENGINE GOVERNOR

<input type="checkbox"/> ELECTRONIC	Standard
FREQUENCY REGULATION, NO-LOAD TO FULL LOAD	Isochronous
STEADY STATE REGULATION	±0.25%

LUBRICATION SYSTEM

TYPE OF OIL PUMP	Gear
OIL FILTER	Full flow, Cartridge
CRANKCASE CAPACITY	11 Liters (11.7 qts.)

COOLING SYSTEM

TYPE OF SYSTEM	Pressurized, Closed Recovery
WATER PUMP	Pre-Lubed, Self-Sealing
TYPE OF FAN	Pusher
NUMBER OF FAN BLADES	6
DIAMETER OF FAN	560 mm (22 in.)
COOLANT HEATER	120V, 1800 W

FUEL SYSTEM

FUEL	#2D Fuel (Min Cetane #40) (Fuel should conform to ASTM Spec.)
FUEL FILTER	5 Micron
FUEL INJECTION PUMP	Bosch, Unit type cam driven
FUEL PUMP	Mechanical
INJECTORS	Multi-Hole, Nozzle Type
ENGINE TYPE	Direct Injection
FUEL LINE (Supply)	6.35 mm (0.25 in.)
FUEL RETURN LINE	6.35 mm (0.25 in.)

ELECTRICAL SYSTEM

BATTERY CHARGE ALTERNATOR	20 Amps at 12 V
STARTER MOTOR	12 V
RECOMMENDED BATTERY	12 Volt, 700 CCA, 27F
GROUND POLARITY	Negative

Rating definitions - Standby: Applicable for supplying emergency power for the duration of the utility power outage. No overload capability is available for this rating. (All ratings in accordance with BS5514, ISO3046 and DIN6271). Prime (Unlimited Running Time): Applicable for supplying electric power in lieu of commercially purchased power. Prime power is the maximum power available at variable load. A 10% overload capacity is available for 1 hour in 12 hours. (All ratings in accordance with BS5514, ISO3046, ISO8528 and DIN6271).

OPERATING DATA

	STANDBY				PRIME			
	SD060				SD060			
GENERATOR OUTPUT VOLTAGE/KW-60Hz	Rated AMP				Rated AMP			
120/240V, 1-phase, 1.0 pf	60			250	54			225
120/208V, 3-phase, 0.8 pf	60			208	54			187
120/240V, 3-phase, 0.8 pf	60			180	54			162
277/480V, 3-phase, 0.8 pf	60			90	54			81
600V, 3-phase, 0.8 pf	60			72	54			65
	NOTE: Consult your Generac dealer for additional voltages.							
GENERATOR OUTPUT VOLTAGE/KVA-50Hz	Rated AMP				Rated AMP			
110/220V, 1-phase, 1.0 pf	48			218	43			195
115/200V, 3-phase, 0.8 pf	60			173	54			156
100/200V, 3-phase, 0.8 pf	60			173	54			156
231/400V, 3-phase, 0.8 pf	60			87	54			78
	NOTE: Consult your Generac dealer for additional voltage							
MOTOR STARTING KVA	480V				480V			
Maximum at 35% instantaneous voltage dip with standard alternator; 50/60 Hz	<u>208/240/416V</u>		92/110		<u>208/240/416V</u>		92/110	
			122/146				122/146	
FUEL	480V				480V			
Fuel consumption—60 Hz	25%	50%	75%	100%	25%	50%	75%	100%
Load gal./hr.	1.35	2.63	3.85	5.0	1.21	2.37	3.46	4.5
liters/hr.	5.1	9.96	14.56	18.91	4.59	8.96	13.1	17.02
Fuel consumption—50 Hz	1.08	2.1	3.08	4.0	0.97	1.89	2.77	3.6
gal./hr.	4.08	7.96	11.65	15.13	3.67	7.17	10.48	13.62
liters/hr.	40"				40"			
Fuel pump lift								
COOLING								
Coolant capacity	System - (US gal. (lit.))		4.5 (17.0)		4.5 (17.0)		4.5 (17.0)	
	Engine - (US gal. (lit.))		2.75 (10.4)		2.75 (10.4)		2.75 (10.4)	
Coolant flow/min.	60 Hz - (US gal. (lit.))		28 (106)		28 (106)		28 (106)	
	50 Hz - (US gal. (lit.))		23 (87)		23 (87)		23 (87)	
Heat rejection to coolant 60 Hz full load	BTU/hr.		120,500		96,500		96,500	
Heat rejection to coolant 50 Hz full load	BTU/hr.		96,500		79,000		79,000	
Inlet air	60 Hz - cfm (m ³ /min.)		7500 (212.4)		7500 (212.4)		7500 (212.4)	
	50 Hz - cfm (m ³ /min.)		6225 (176.3)		6225 (176.3)		6225 (176.3)	
Max. air temperature to radiator	°C (°F)		60 (140)		60 (140)		60 (140)	
Max. ambient temperature	°C (°F)		50 (122)		50 (122)		50 (122)	
COMBUSTION AIR REQUIREMENTS								
Flow at rated power	60 Hz - cfm (m ³ /min.)		208 (5.9)		177 (5.0)		177 (5.0)	
	50 Hz - cfm (m ³ /min.)		177 (5.0)		142 (4.0)		142 (4.0)	
EXHAUST								
Exhaust flow at rated output	60 Hz - cfm (m ³ /min.)		533 (18.0)		450 (15.3)		450 (15.3)	
	50 Hz - cfm (m ³ /min.)		450 (15.0)		390 (12.8)		390 (12.8)	
Max recommended back pressure	Inches Hg		2.2		2.2		2.2	
Exhaust temperature 60 Hz (full load)	°F (°C)		964 (518)		895 (480)		895 (480)	
Exhaust outlet size			2.5" O.D. Turbo		2.5" O.D. Muffler		2.5" O.D. Muffler	
ENGINE								
Rated RPM	60 Hz / 50 Hz		1800 / 1500		1800 / 1500		1800 / 1500	
HP at rated KW	60 Hz / 50 Hz		93 / 80		80 / 64		80 / 64	
Piston speed	60 Hz - ft./min. (m/min.)		1230 (375)		1230 (375)		1230 (375)	
	50 Hz - ft./min. (m/min.)		1025 (312)		1025 (312)		1025 (312)	
BMEP	60 Hz / 50 Hz		227 / 227		189 / 189		189 / 189	
DERATION FACTORS								
Temperature	4.1% for every 10°C above - °C		25		25		25	
	2.4% for every 10°F above - °F		77		77		77	
Altitude	0.8% for every 100 m above - m		1067		1067		1067	
	2.6% for every 1000 ft. above - ft.		3500		3500		3500	

- High Coolant Temperature Automatic Shutdown
- Low Coolant Level Automatic Shutdown
- Low Oil Pressure Automatic Shutdown
- Overspeed Automatic Shutdown (Solid-state)
- Crank Limiter (Solid-state)
- Oil Drain Extension
- Radiator Drain Extension
- Factory-Installed Cool Flow Radiator
- Closed Coolant Recovery System
- UV/Ozone Resistant Hoses
- Rubber-Booted Engine Electrical Connections
- Coolant Heater
- Secondary Fuel Filter
- Fuel Lockoff Solenoid
- Stainless Steel Flexible Exhaust Connection
- Battery Charge Alternator
- Battery Cables
- Battery Tray
- Vibration Isolation of Unit to Mounting Base
- 12 Volt, Solenoid-activated Starter Motor
- Air Cleaner
- Fan Guard
- Control Console
- Radiator Duct Adaptor
- Isochronous Governor

OPTIONS

- **OPTIONAL COOLING SYSTEM ACCESSORIES**
 - 208/240V Coolant Heater
- **OPTIONAL FUEL ACCESSORIES**
 - Flexible Fuel Lines
 - UL Listed Fuel Tanks
 - Base Tank Low Fuel Alarm
 - Primary Fuel Filters
- **OPTIONAL EXHAUST ACCESSORIES**
 - Critical Exhaust Silencer
- **OPTIONAL ELECTRICAL ACCESSORIES**
 - 2A Battery Charger
 - 10A Dual Rate Battery Charger
 - Battery, 12 Volt, 135 A.H.
- **OPTIONAL ALTERNATOR ACCESSORIES**
 - Alternator Upsizing
 - Alternator Strip Heater
 - Alternator Tropicalization
 - Voltage Changeover Switch
 - Main Line Circuit Breaker
- **CONTROL CONSOLE OPTIONS**
 - Digital Controller H100 (Bulletin 0172110SBY)
- **ADDITIONAL OPTIONAL EQUIPMENT**
 - Automatic Transfer Switch
 - Remote Relay Panels
 - Unit Vibration Isolators
 - Oil Make-Up System
 - Oil Heater
 - 5 Year Warranties
 - Export Boxing
 - GenLink® Communications Software
- **OPTIONAL ENCLOSURE**
 - Weather Protective
 - Sound Attenuated
 - Aluminum and Stainless Steel
 - Enclosed Muffler

Distributed by:

